

Canon



Large Format Printer

W8200

User's Guide

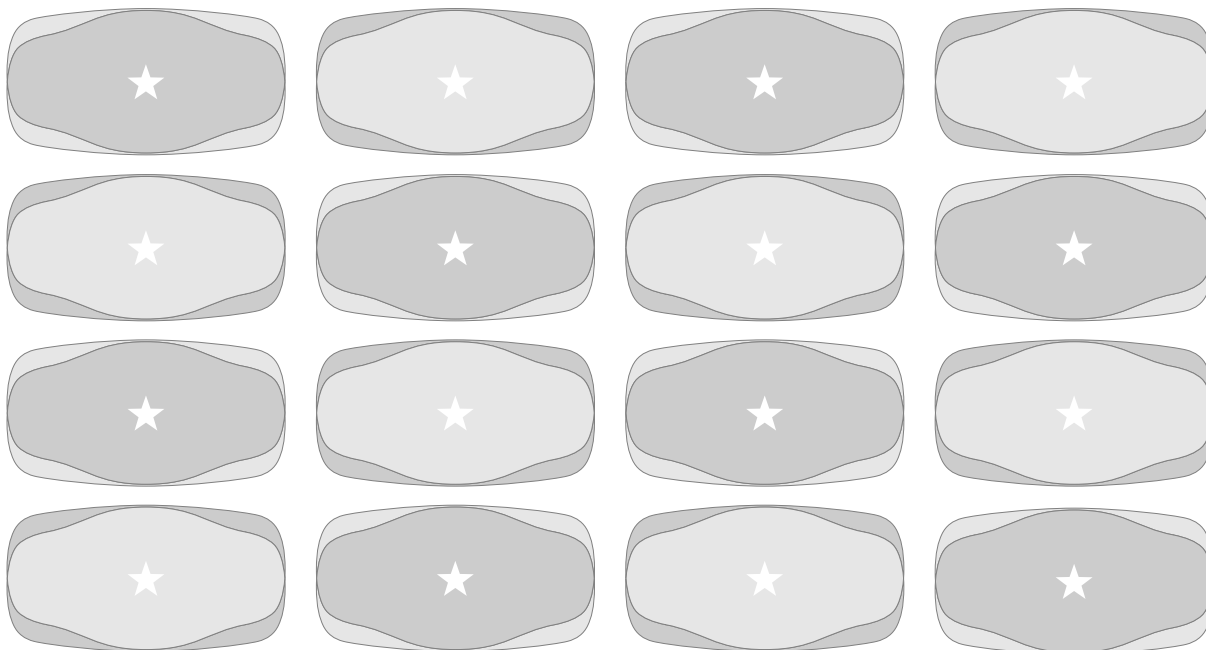

Copyright ©2003 Canon Inc. all rights reserved.

- Unauthorized transfer or duplication of all or any part of this document is prohibited.
- The content of this document is subject to change without notice.
- Every effort has been made to ensure that the information contained in this guide is correct. If any error or omission is found, contact us directly or an authorized Canon representative.
- Canon is not responsible for any damages, direct or indirect, arising from or related to the use of this printer.

Trademarks

- Canon and the Canon logo are trademarks of Canon Inc.
- Microsoft®, Windows®, Windows NT® and MS-DOS® are registered trademarks of Microsoft Corporation in the United States and/or other countries.
- Apple, AppleTalk, EtherTalk, LocalTalk, and Macintosh are trademarks of Apple Computer, Inc., in the U.S.A.
- Other brand and product names may be trademarks or registered trademarks of their respective companies.

Notations About Text

Conventions

To ensure the safe and most efficient use of this printer, important information is provided under the headings listed below. Before you use this guide, make sure that you understand what these headings mean and remember the important information described under these headings.



Warning

- Failure to follow these instructions could result in fatal or serious injury. Always remember and follow the guidelines and advice described under this heading to ensure your own safety and the safety of other people working around the printer.



Caution

- Failure to follow these instructions could lead to mistakes in the use of printer and result in minor injury or serious damage to the printer. Always remember and follow the guidelines and advice described under this heading to ensure safe use of the printer.



Important

- Instructions and guidelines for operation of the printer provided under this heading describe restrictions and other important information which if ignored could cause minor damage to the printer or other equipment or result in the loss of valuable data. Always remember and follow the guidelines and advice under this heading to avoid mistakes in procedure.



Note

- Information under this heading includes tips and hints that will help you avoid minor problems and use the printer more efficiently.

Regulations for this product

FCC Regulations

Canon Large Format Printer, Model K90029
IEEE1394 Expansion Board EB-01, Model K90023
Hi-Speed USB Board EB-02, Model K90035

This device complies with Part 15 of the FCC Rules. Operation is subject to the following two conditions: (1) This device may not cause harmful interference, and (2) this device must accept any interference received, including interference that may cause undesired operation.

Note: This equipment has been tested and found to comply with the limits for class B digital device, pursuant to Part 15 of the FCC Rules. These limits are designed to provide reasonable protection against harmful interference in a residential installation. This equipment generates, uses and can radiate radio frequency energy and, if not installed and used in accordance with the instructions, may cause harmful interference to radio communications. However, there is no guarantee that interference will not occur in a particular installation. If this equipment does cause harmful interference to radio or television reception, which can be determined by turning the equipment off and on, the user is encouraged to try to correct the interference by one or more of the following measures:

- Reorient or relocate the receiving antenna.
- Increase the separation between the equipment and receiver.
- Connect the equipment into an outlet on a circuit different from that to which the receiver is connected.
- Consult the dealer or an experienced radio/TV technician for help.

Use of shielded cable is required to comply with Class B limits in Subpart B of Part 15 of FCC Rules.

Do not make any changes or modifications to the equipment unless otherwise specified in the manual. If such changes or modifications should be made, you could be required to stop operation of the equipment.

Canon U.S.A. Inc.

One Canon Plaza, Lake Success, NY 11042, U.S.A.

Tel No. 516-328-5600

Canadian Radio Interference Regulations

This digital apparatus does not exceed the Class B limits for radio noise emissions from digital apparatus as set out in the interference-causing equipment standard entitled “Digital Apparatus”, ICES-003 of the Industry and Science Canada.

Cet appareil numérique respecte les limites de bruits radioélectriques applicables aux appareils numérique de Classe B prescrites dans la norme sur le matériel brouiller: “Appareils Numériques”, NMB-003 édictée par l’Industrie et Sciences Canada.

International ENERGY STAR® Program

As an ENERGY STAR® Partner, Canon Inc. has determined that this product meets the ENERGY STAR® guidelines for energy efficiency. The international ENERGY STAR® Office Equipment Program is a global program that promotes energy saving through the use of computers and other office equipment. The program backs the development and dissemination of products with functions that effectively reduce energy consumption. It is an open system in which businesses can participate voluntarily. The targeted products are office equipment such as computers, monitors, printers, facsimiles, and copiers. Their standards and logos are uniform among participating nations.



Safety Warnings and Precautions

Read and follow all the warnings and guidelines described below to prevent the hazards of fire or electrical shock and ensure safe use of this printer.



Warning

■ Location



- The electrical contacts inside the printer become extremely hot during normal operation. To avoid causing a fire, never store flammable substances like alcohol, thinner, etc. near the printer.

■ Power Supply



- To avoid personal injury from an electrical shock, never handle the power cord or plug when your hands are wet.



- To avoid causing a fire or serious electrical shock, make sure that the power plug is securely and completely inserted into the power source.



- To avoid causing a fire or serious electrical shock, always use the power cord provided with this printer, and do not use this power cord with any other electrical device.



- To avoid a fire or serious electrical shock caused by a short circuit, avoid damaging the AC adapter cord or the power cord. Never attempt to modify the power cord in any way. Never apply force to the cord by pulling on it, and never place a heavy object on the power cord.



- To avoid a fire or serious electrical shock, connect the printer power cord to an independent power source that is not shared by other equipment or appliances.



- To avoid a fire or serious electrical shock, never knot the power cord or wrap it around itself.



- To avoid a fire hazard, occasionally disconnect the power cord from the printer and the power supply and use a soft dry cloth to clean the cord connectors and the connection points. Leaving the cord plugged in and not cleaned for a long period, especially in an area subject to dust, oil, and high humidity, could cause the insulation material to deteriorate.

■ In an Emergency ...



- To avoid a fire or serious electrical shock, if the printer emits smoke or a strange odor, immediately press the Power button to switch the printer off and unplug the power cord from the power supply. Discontinue using the printer and call for service.

■ Cleaning the Printer



- Use only a damp, clean cloth to clean the surfaces of the printer. The electrical contacts inside the printer become hot during normal operation. To avoid a fire or serious electrical shock, never use alcohol, benzene, thinner, or any other type of flammable liquid cleaner to clean the printer.

■ Pacemakers

- This printer generates a low magnetic field. If anyone wearing a pacemaker experiences discomfort while working around the printer should leave the area. Consult a physician before continuing to work around the printer.



Caution

■ Printer location



- To avoid damage to the printer or possible personal injury, place the printer on a flat, stable surface that is safe from sudden shocks or strong vibrations to ensure that it will not fall.



- To avoid damage to the printer which could result in a fire or electrical shock, place the printer in a location where it is not exposed dust, direct sunlight, high temperature, or high humidity. Use the printer location in an environment where temperature and humidity are within the ranges of 5°C~35°C (41°F~95°F) and 10~90% RH (with no condensation).



- To avoid anything entering the printer and causing a fire, never place the printer on a heavy wool or shag carpet.



- To avoid the hazard of a dangerous fire, keep the area around the power supply where the printer power cord is connected so you can disconnect it immediately if the printer starts operating abnormally (emitting smoke or odd noises, etc.).

Locate the printer as close as possible to the power supply and make sure the power supply is easily accessible.



- To ensure normal operation of the printer and avoid possible damage, never install the printer near large office equipment or any other type of electrical device that emits a strong magnetic field.

■ Moving the Printer



- The W8200 alone weighs 85 kg (187 lb.). To prevent painful back or other injury, at least two people (three recommended with the third person supporting the middle from behind), one on each the left and right side, are required to move the printer.

When you move the printer, avoid tangling your feet with the box and other packing material which could cause you to tip over.



- When lifting and moving the printer, separate the printer from the stand, and firmly grip the handles provided below each side of the printer. Gripping either side of the printer at any other location is not safe and could cause the printer to fall and cause personal injury.

■ Power Supply



- To avoid damaging the power plug, which could cause a short circuit and cause a fire or electrical shock, never pull on the power cord to unplug the cord from the power supply. Always grip the plug to remove it from the power supply.



- To avoid a fire or electrical shock, do not use an extension cord.



- To prevent fire or electrical shock, never use a power supply source other than the one rated for the printer in the country where you purchased the printer.

AC 100-240 V, 50/60 Hz

■ Cleaning the Printer



- To avoid minor burns or minor injury from moving parts, before cleaning the printer always press the Power button to switch off the printer then unplug the power cord from the power supply and allow the electrical contacts inside the printer to cool.

■ Printhead and Ink Tanks



- Store the ink tanks out of the reach of small children. If a child accidentally ingests ink from an ink tank, contact a physician immediately.



- To avoid staining clothing or your work area with spilled ink, never shake or drop the printhead or an ink tank.



- The electrical contacts of the printhead become extremely hot during normal operation. To avoid minor burns, never touch the electrical contacts after removing the printhead from the printer.

Contents

About These Manuals	i
Notations About Text	ii
Conventions	ii
Abbreviations	iii
Legal Notice	iii
Regulations for this product	iv
FCC Regulations	iv
Canadian Radio Interference Regulations	v
International ENERGY STAR® Program	v
Safety Warnings and Precautions	vi
Contents	x

Chapter 1 Before Using the Printer

Printer Part Names	1-2
Printer Main Unit	1-2
Media Take-up Unit (option)	1-8
Switching the Printer On and Off	1-9
Switching the Printer On	1-9
Switching the Printer Off	1-10
Setting the Printer Online and Offline	1-11
Setting the Printer Online	1-11
Setting the Printer Offline	1-12

Chapter 2 Print Media You Can Use

Print Media That Can Be Used	2-2
Types of Print Media	2-2
Paper Sizes	2-5
Printing Area	2-7
Handling Print Media	2-7
Loading Roll Media	2-8
Selecting the Media Source	2-8
Loading the Roll Media	2-9
Selecting the Roll Media Type	2-18
Loading Cut Sheets	2-19
Selecting the Cut Sheet Source	2-19
Loading Cut Sheets	2-21
Select the Cut Sheet Type	2-26
High Quality Printing on Film	2-27
Adjusting Printhead Height	2-27
Aligning the Printhead	2-30
Re-adjusting Printhead Height	2-30
Using the Media Take-up Unit	2-31

Settings for Using the Media Take-up Unit	2-32
Loading Roll Media	2-33
Removing Printed Media from the Media Take-up Unit	2-39
Disabling the Media Take-up Unit	2-43

Chapter 3 Printing from Windows

Printing	3-2
Print Procedure	3-2
Canceling a Print Job	3-4
Viewing Online Help	3-5
Opening Online Help	3-5

Chapter 4 Printing from a Macintosh

Printing	4-2
Selecting the Printer	4-2
Print Procedure	4-6
Canceling a Print Job	4-7
Canceling a Background Print Job	4-7
Canceling a Foreground Print Job	4-12
Viewing Help	4-13
Opening Help	4-13

Chapter 5 Using the Operation Panel

What's On the Operation Panel?	5-2
Reading the Display	5-2
Using the Operation Panel Buttons	5-4
Reading Operation Panel Lamps	5-6
Function Menus	5-7
Printer Function Priorities	5-7
Menu Flow Summaries	5-7
How to Perform Menu Settings	5-8
Making Settings	5-8
Menu Settings Summary Tables	5-10
Main Menu	5-10

Chapter 6 Maintenance

Replacing Ink Tanks	6-2
When to Replace an Ink Tank	6-2
Handling Ink Tank Precautions	6-3
Replacing an Ink Tank	6-4
Caution About Using Refilled Ink Tanks for This Printer	6-8
Switching Off Ink Level Detection	6-8
Executing Print Job	6-8

Cleaning the Printer	6-9
Cleaning the Printer Surfaces	6-9
Cleaning Inside the Upper Cover	6-11
Cleaning the Paper Restraint	6-14
Cleaning the Carriage Rail	6-16
Replacing the Printhead	6-19
Handling Printhead Precautions	6-19
How to Replace the Printhead	6-20

Chapter 7 Troubleshooting

Having a Problem?	7-2
Printer Not Operating Correctly	7-3
Cannot Print	7-3
Printing Does Not Start	7-6
Printing Halts During Print Job	7-7
Print Job Results Abnormal	7-9
Poor Print Quality	7-9
Print Results Do Not Match Print Job Content	7-11
Colors Wrong	7-11
Other Problems	7-12
Message Is Displayed	7-13
Removing Paper Jams	7-19
Removing a Roll Media Jam	7-19
Removing a Cut Sheet Jam	7-28
Checking the Print Status	7-31
Cleaning the Printhead	7-33
Types of Printhead Cleaning	7-33
Printhead Cleaning Procedure	7-33
Aligning the Printhead	7-35
Adjusting Amount of Media Feed	7-38
Reducing the Amount of Cut Waste	7-40
Replacing the Cutter Blade	7-42

Chapter 8 Other Important Information

Options	8-2
Media Take-up Unit	8-2
USB 2.0 Expansion Board	8-2
IEEE1394 Expansion Board	8-3
Roll Holder Sets	8-3
Consumables	8-4
Print Media	8-4
Ink Tanks	8-5
Printhead	8-5
Cutter Blade	8-6
Updating the Firmware	8-7

Obtaining the Firmware Update	8-7
Confirming the Firmware Version	8-7
Uninstalling the Software	8-8
Deleting Old USB/IEEE1394 Printer Drivers	8-8
Uninstalling the Printer Driver	8-10
Uninstalling GARO Status Monitor	8-11
Uninstalling an LPR Port	8-11
Uninstalling the GARO Device Setup Utility	8-12
Specifications	8-13
Index	8-16

1

Before Using the Printer

This section describes printer parts and procedures you should know before you use the printer.

Printer Part Names

Printer Main Unit

■ Front View

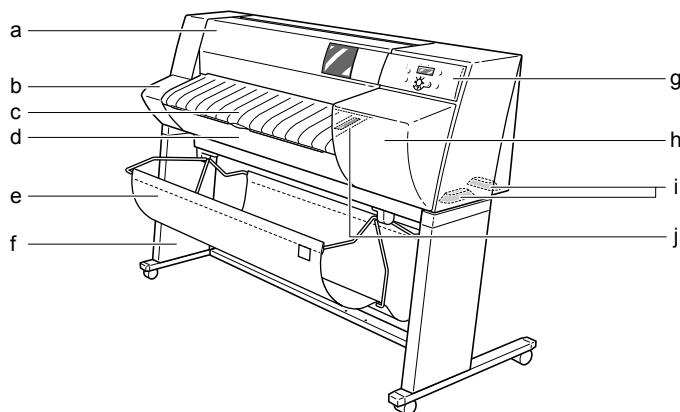

a Upper cover

Open to install the printhead or to remove paper jams inside the printer.
(→ P.6-21, P.7-22)

b Left cover

Open to replace the mist filter. (→ Filter Instructions provided with filter)

c Tray

Used to feed cut sheets and to receive printed output from the printer.
Open to load roll media. (→ P.2-9)

d Roll media tray

Holds the roll holder and roll media. Pull out to load roll media.
(→ P.2-10)

e Output Stacker

A cloth tray to hold printed media output from the printer.

f Stand

A stand mounted on four casters to support the printer main unit. The output stacker, or optional Media Take-up Unit, can be mounted inside the stand.

g Operation panel

Provides the Power button, Online button, LCD display, and other important buttons used to operate the printer. For details, see Chapter 5, “Using the Operation Panel Buttons” (→ P.5-4).

h Right cover

Open to replace ink tanks. This cover is normally locked. In order to replace ink tanks, this cover may be unlocked automatically by selecting “Rep. Ink Tank” from the MAIN MENU on the printer operation panel.

i Lift handles

Grasp the handles provided on the left and right side to lift or move the printer.

j Roll media window

Allows you to visually check the amount of media remaining on the roll.

■ Back View

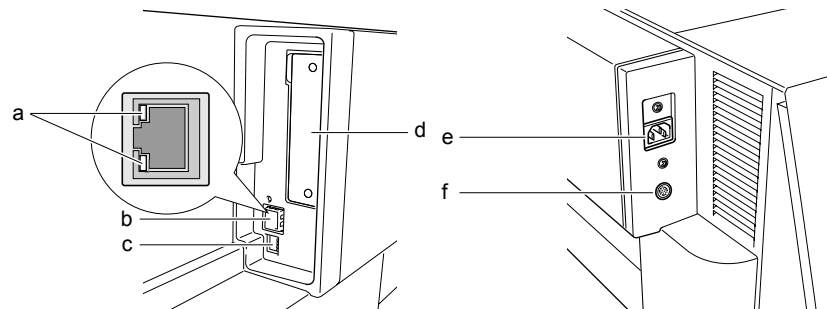

a LINK lamp

Located on the left side of the port, indicates the communication status of the LAN. Lights green for a 100Base connection or lights yellow for a 10Base connection. (→ Setup Guide)

b LAN port

Provides a connection point for a LAN cable connected to a network hub. (→ Setup Guide)

c DIP switches

Allows the switching of communication modes for the LAN. (→ Setup Guide)

d Slot

Provided for installation of either the USB 2.0 or IEEE1394 expansion board. To install, remove the two screws. (→ Setup Guide)

e Power connector

Provides a connection point for the printer power cord.

f Media Take-up Unit connector

Provides a connection point for the power cord of the Media Take-up Unit.

■ **Top View (Inside)**

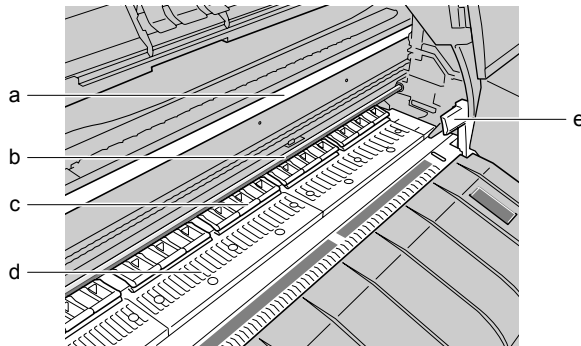

a Guide rail

An important part for the movement of the carriage.

b Carriage rail

Provides the path for the carriage as it moves from side to side.

c Paper restraint

Required for media and paper output in the paper path.

d Platen

Supports the paper from below while the printhead moves from side to side on the surface of the paper during printing.

e Paper release lever

Releases the media in the paper path. Upper this lever to open the paper restraint when you need to load a cut sheet, feed a cut sheet manually, or clean inside the printer. (→ P.2-21)

■ Carriage (Inside Upper Cover)

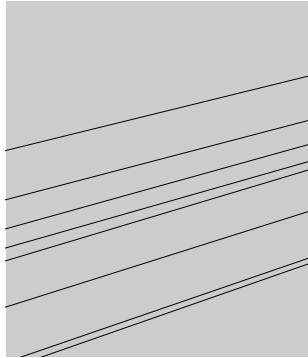

a Carriage cover

Protects the carriage. Open the carriage cover to install the printhead. (→ Setup Guide)

b Printhead lock cover

Holds the printhead in place. Open to install the printhead. (→ Setup Guide)

c Printhead

Equipped with the nozzles that supply the inks for printing. This important part is not installed before shipping, so you must install it before you can use the printer. (→ Setup Guide)

d Printhead lock lever

This lever locks and holds the printhead lock cover in place. Open to install the printhead. (→ Setup Guide)

e Printhead height adjustment lever

Lever used to adjust the height of the printhead. For high quality printing, the lever position must be adjusted for the media in use. (→ P.2-29)

f Carriage

Holds the printhead and moves it left and right across the paper during printing.

■ Inside the Tray

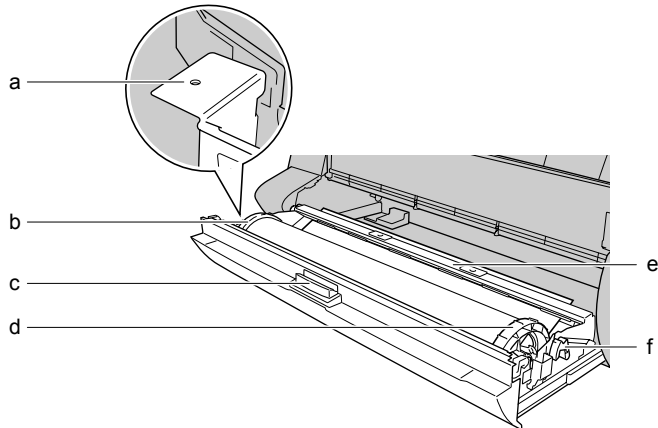

a Belt stopper holder

Provides a hole for the belt stopper screw to fasten the belt stopper for storage. (→ Setup Guide)

b Roll stopper

Holds the roll media on the roll holder.

c Tray open lever

Pull on this lever to unlock the roll media tray so you can draw it out of the printer.

d Roll holder

Used when loading roll media in the printer.

e Paper guide

An important part in the media feed path. When loading roll media, pass the sheet between the paper guide. (→ Setup Guide)

f Roll release lever

Releases the pressure of the paper guide on the media in the paper path. Use this lever when loading roll media or when removing jams. (→ P.2-12)

■ Inside the Right Cover

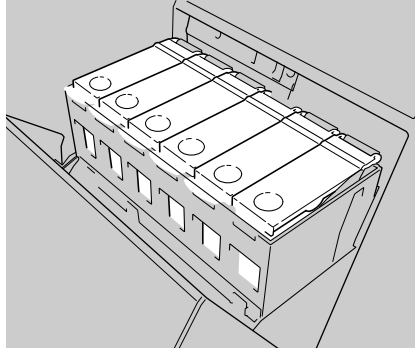

- a Bk Ink Tank**
- b PC Ink Tank**
- c C Ink Tank**
- d PM Ink Tank**
- e M Ink Tank**
- f Y Ink Tank**

These tanks hold the ink. The ink tanks are not installed before shipping, so you must install all the ink tanks before you can use the printer.

- g Bk Ink Tank Cover**
- h PC Ink Tank Cover**
- i C Ink Tank Cover**
- j PM Ink Tank Cover**
- k M Ink Tank Cover**
- l Y Ink Tank Cover**

The ink tank covers protect the tanks and lock them in place. To replace an ink tank, on the operation panel select “Rep. Ink Tank” from the MAIN MENU to release the right cover. Open the right cover then raise the ink tank cover.

Media Take-up Unit (option)

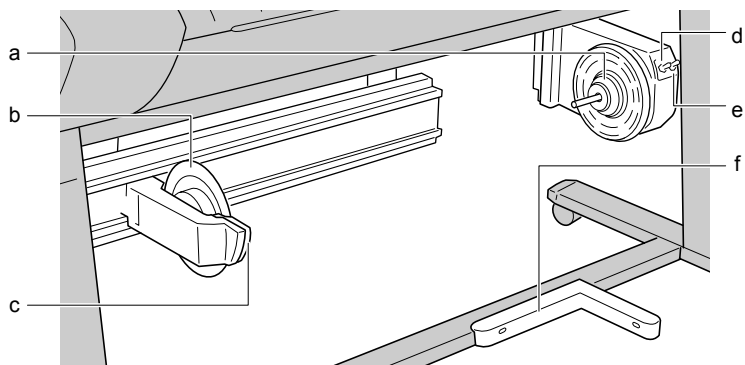

a Take-up holder

Holds the take-up media core.

b Slider holder

Locks and holds the take-up media core in place.

c Slide holder release lever

While pressing on this lever, move the slide holder to the left.

d Take-up mode switch

Switches the take-mode between automatic and manual.

e Take-up switch

Switches media take-up on and off when the take-up mode switch is set for manual.

f Sensor unit

Senses the presence of the print media. When the take-up mode switch is set for automatic and a sheet of media blocks this sensor, the take-up operation starts.

Switching the Printer On and Off

Follow the procedure below to switch the printer on and off.

The examples below demonstrate normal operation of the printer after it is set up and ready for normal operation. If the printer has not been set up completely, follow the procedures in the Setup Guide to complete the setup procedures before you execute the procedures below.

Switching the Printer On

Switch on the printer before you execute a print job from the computer.

- 1 Press the Power button.

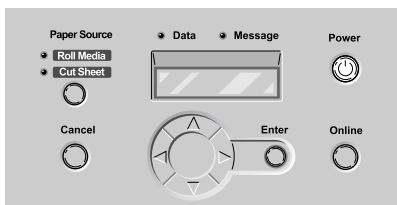

The Online lamp and Message lamp flash for a few seconds while the printer warms up. After the printer has warmed up, if media is loaded in the printer the Online lamp lights and remains on, and “Online” is displayed. The printer is ready to print.

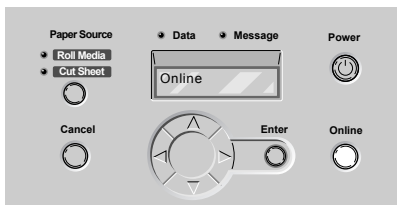

If no print media is loaded in the printer when the printer is switched on, “Offline” is displayed and the printer waits for you to load media in the printer.

The Message lamp flashes when a message is displayed. Read the message and perform the required procedure. (→ “Message Is Displayed” P.7-13)

If the display or Online lamp do not light, check the power cord connections at the printer and the power supply and make sure that they are secure. (→ Setup Guide)

Switching the Printer Off

When you are finished using the printer, follow this procedure to switch the printer off.

Important

- To prevent damaging the printer or losing valuable data, never switch it off or disconnect the power cord while the printer is operating.
- If the roll media is not to be used for a week or so, open the roll media tray and take up the roll media. Leaving the roll media at the standby position for a week or longer could cause the media to deteriorate.

- 1** Check the display to make sure that a print job is not in progress.

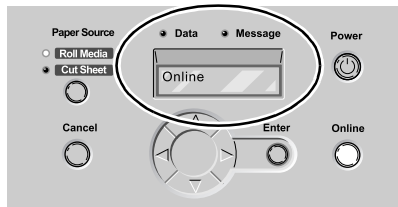

If you see an error message displayed, follow the procedure to correct the problem, and make sure the print job has completed. If a print job is in progress, wait for the print job to complete before switching off the printer.

- 2** Press and hold down the Power button for over 1 second until the Online lamp goes off, and then release the button.

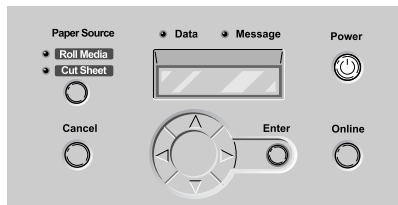

“Please wait ..” is displayed for a few seconds, then the printer goes off.

Setting the Printer Online and Offline

While the printer is on, it can be set online or offline.

When the printer is online, the printer can accept data from the computer to execute a print job. The printer enters the online mode automatically every time the printer is switched on.

When the printer is offline, the printer cannot receive data to execute a print job. The printer goes offline when the printer is switched on with no media loaded, or the printer can be set offline with the operation panel in order to use the operation panel menus or to pause a print job temporarily. The printer also enters the offline mode automatically when a message alerts you about a problem so you can perform the procedure to correct the problem.

Note

- If the printer does not receive print data for more than 20 minutes, or if the operation panel is not pressed, the printer automatically enters the sleep mode to conserve power. As soon as the printer receives print data, or if a button on the operation panel is pressed, the printer leaves the sleep mode. The printer requires about 5 seconds to return to full operation.

Setting the Printer Online

Follow this procedure to set the printer online.

- 1 Press the Online button. “Online” is displayed on the operation panel.

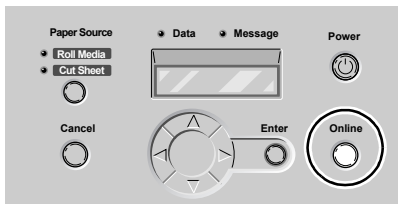

The printer can print while the Online lamp is on.

While no media is loaded in the printer, or while a message is displayed on the operation panel, the printer will not enter the online mode even when the Online button is pressed. After the problem is corrected, the printer enters the online mode automatically.

Note

- Pressing the Online button repeatedly cycles the printer through three modes in this order: Online→ Offline→ MAIN MENU.

Setting the Printer Offline

Follow the procedure below to set the printer offline.

- 1 Press the Online button. The Online lamp goes off.

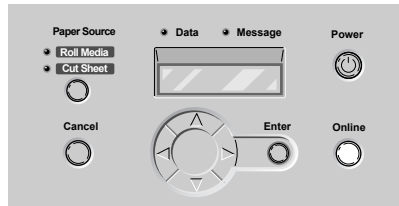

When the Online lamp goes off, the printer is offline.



Note

- Pressing the Online button repeatedly cycles the printer through three modes in this order: Online→ Offline→ MAIN MENU.

2

Print Media You Can Use

This chapter describes the types of print media that can be used and how to load each type.

Print Media That Can Be Used

A variety of print media can be used with this printer. The size and types of paper or special media, the print area for each type, and other details are described below.



Important

- With some print media, the hue of some colors may change slightly when the ink on the surface of the media has dried completely. In such a case, wait for the ink to dry completely before handling the media.



Note

- For more details about Canon print media, please refer to the instructions provided with each media package.

Types of Print Media

The types of paper and other print media are described below.

Dye Ink	Pigment Ink
Plain Paper	Heavy Coated Paper
Coated Paper	Photo Glossy Paper
Heavy Coated Paper	Photo Semi-Glossy Paper
Glossy Paper	Synthetic Paper (Non-Adhesive)
Photo Glossy Paper	Synthetic Paper (Adhesive)
Photo Semi-Glossy Paper	Back Light Film
Glossy Film	Flame-Resistant Cloth
Back Print Film	—
Proofing Paper	—

■ Plain Paper

Inexpensive paper for use. Suitable for printing monochrome, proofs, and low density color images.



Note

- Compared to other types of media, the stability of plain paper is slightly less because it is more susceptible to change by temperature and humidity.
- You can also use plain, cut sheet copy paper (64 ~ 105 g/m²) intended for use on copy machines.

■ Coated Paper

Specially coated for use, coated paper reproduces brilliant colors without blurring.

■ Heavy Coated Paper

Specially coated for use, heavy coated paper is thicker than coated paper, making it suitable for printing POP artwork and other graphic designs.

■ Glossy Paper

Paper with a glossy finish and high degree of white color. This media is suitable for printing high density graphic images like photographs and other images that require extremely high quality finishing.

■ Glossy Film

Coated with a film base that reproduces color even more brilliantly than glossy paper. This media is ideal for reproducing brilliant colors for graphic and photographic images that require the best possible quality.

■ Photo Glossy Paper

Best quality paper with a high degree of white and extremely high gloss finish, making it ideal for photographs. Realizes the best reproduction of photographic images shot with traditional silver-halide film.

■ Photo Semi-Glossy Paper

High quality semi-gloss paper with a subdued degree of white. Ideal for subduing surface light reflections when you want to give a soft finish to photographs.

■ Proofing Paper

Media used to achieve best results in color hues and gloss. Ideal for testing prints to confirm changed color or finishing settings.

■ Back Print Film

The front side is glossy like a photograph and the reverse side is white, semi-transparent and slightly rough to the touch. The finish of the front side is like a photograph and ideal for display with a backlighting device. The image is printed from the reverse side, protecting the front side so laminate processing is not required.

■ Synthetic Paper (Non-Adhesive)

Matte finish with a polypropylene base, making it extremely resistant to water and light, yet very economical. Due to its laminated processing, you can use this paper for signs, posters, etc. for display outdoors for short periods. Extremely flexible yet difficult to crease, this paper is ideal for portable maps and diagrams for practical use.

■ Synthetic Paper (Adhesive)

Matte finish with a polypropylene base, making it extremely resistant to water and light, yet very economical. Due to its laminated processing, you can use this paper for signs, posters, etc. for display outdoors for short periods. The reverse side is coated with adhesive, making this paper easy to paste on bulletin boards.

■ Back Light Film

White translucent film ideal for displays that use electric backlighting. Use a pigment printer to print on the front side of this paper for best results. You can achieve a lighting effect in the day time, even without backlighting.

■ Flame-Resistant Cloth

A polyester base cloth media. The cloth texture of this media makes it ideal for printing drapes and wall tapestries. This media is also extremely flame resistant, making it safe for use indoors.



Important

- When printing on backlight film or synthetic paper in Standard mode, fine horizontal lines may appear in the image. When using either of these print media, in the printer driver be sure to set the Print Quality setting for High, or Highest.

Paper Sizes

The below table lists the paper sizes and feed methods that can be used with this printer.

■ Roll Media

This table lists roll media with maximum diameters of 130 mm (5.1 in.), media core inside diameter of 2 inches, and 3 inches that can be used in this printer.

Name	Size (Width)
ISO A0	841.0 mm (33.11 in.)
ISO A1	594.0 mm (23.39 in.)
ISO A3	297.0 mm (11.69 in.)
ARCH 36"	914.4 mm (36 in.)
ARCH 30"	762.0 mm (30 in.)
ARCH 24"	609.6 mm (24 in.)
Non-Category 42"	1067 mm (42 in.)
Non-Category 44"	1118 mm (44 in.)

■ Cut Sheets

The following Cut Sheets are available.

Name	Size (Width)
ISO A0	841.0 x 1189.0 mm (33.11 x 46.81 in.)
ISO A1	594.0 x 841.0 mm (23.39 x 33.11 in.)
ISO A2	420.0 x 594.0 mm (11.69 x 23.39 in.)
ISO A3+	329.0 x 483.0 mm (12.95 x 19.02 in.)
ISO A3	297.0 x 420.0 mm (11.69 x 16.54 in.)
ISO A4	210.0 x 297.0 mm (8.27 x 11.69 in.)
ISO B0	1000.0 x 1414.0 mm (39.37 x 55.68 in.)
ISO B1	707.0 x 1000.0 mm (27.83 x 39.37 in.)
ISO B2	500.0 x 707.0 mm (19.69 x 27.83 in.)
ISO B3	353.0 x 500.0 mm (13.90 x 19.69 in.)
ISO B4	250.0 x 353.0 mm (9.84 x 13.90 in.)
JIS B0	1030.0 x 1456.0 mm (40.56 x 57.31 in.)
JIS B1	728.0 x 1030.0 mm (28.66 x 40.55 in.)
JIS B2	515.0 x 728.0 mm (20.28 x 28.66 in.)
JIS B3	364.0 x 515.0 mm (14.33 x 20.28 in.)
JIS B4	257.0 x 364.0 mm (10.12 x 14.33 in.)
ANSI E	863.6 x 1117.6 mm (34 x 44 in.)
ANSI F	711.2 x 1016.0 mm (28 x 40 in.)
ANSI D	558.8 x 863.6 mm (22 x 34 in.)

Name	Size (Width)
ANSI C	431.8 x 558.8 mm (17 x 22 in.)
ANSI B	279.4 x 431.8 mm (11 x 17 in.)
ANSI B Super	330.2 x 482.6 mm (13 x 19 in.)
ANSI Letter	215.9 x 279.4 mm (8.5 x 11 in.)
ANSI Legal	215.9 x 355.6 mm (8.5 x 14 in.)
ARCHE	914.4 x 1219.2 mm (36 x 48 in.)
ARCHE1	762.0 x 1066.8 mm (30 x 42 in.)
ARCHE2	660.4 x 965.2 mm (26 x 38 in.)
ARCHE3	685.8 x 990.6 mm (27 x 39 in.)
ARCH D	609.6 x 914.4 mm (24 x 36 in.)
ARCH C	457.2 x 609.6 mm (18 x 24 in.)
ARCH B	304.8 x 457.2 mm (12 x 18 in.)
ARCH A	228.6 x 304.8 mm (9 x 12 in.)
DIN C0	917.0 x 1296.0 mm (36.10 x 51.02 in.)
DIN C1	648.0 x 917.0 mm (25.51 x 36.10 in.)
DIN C2	458.0 x 648.0 mm (18.03 x 25.51 in.)
DIN C3	324.0 x 458.0 mm (12.76 x 18.03 in.)
DIN C4	229.0 x 324.0 mm (9.02 x 12.76 in.)
Poster 20" x 30"	508.0 x 762.0 mm (20 x 30 in.)
Poster 30" x 40"	762.0 x 1016.0 mm (30 x 40 in.)
Poster 42" x 60"	1067 x 1524.0 mm (42 x 60 in.)
Poster 44" x 62"	1118 x 1574.8 mm (44 x 62 in.)

Printing Area

This printer prints on roll media and cut sheets in the area defined in the illustration below.

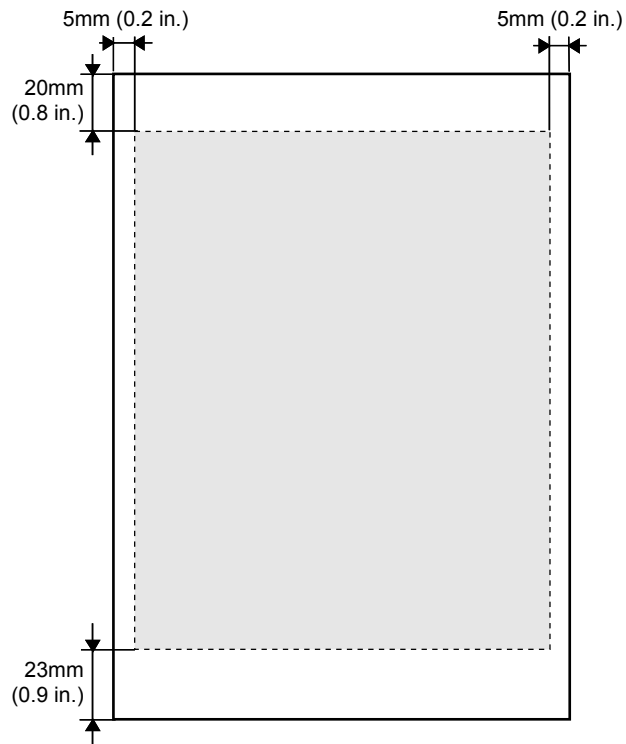

Note

- If you intend to use the Expand Print Area feature in the printer driver, the top and bottom margins should be set for the minimum settings in order to maximize the print area. For more details, refer to the printer driver Help.

Handling Print Media

For details about handling and storing print media, please refer to the instructions provided with the media package.

Loading Roll Media

This is the general procedure for loading a paper cassette.

- Remove all printed roll media or cut sheets from the tray.
- On the operation panel, select the roll media source. (→ P.2-8)
- Load the roll media in the roll media tray. (→ P.2-9)
- On the operation panel, select the Roll Media Type. (→ P.2-16)
- Adjust the amount of media feed. (→ P.7-38)
- Start the print job on the computer. (→ P.3-2, P.4-2)



Important

- Make sure that the printer is switched on when you load roll media in the printer. If the Roll Media Type selection does not match the type of roll media loaded in the printer, this could cause poor print quality.
- Store unused roll media and other media in the original package. Store the package in a cool, dry location that is not exposed to direct sunlight.
- To prevent jams, never open the roll media tray during printing.
- If you switch the printer off with the roll media set, do not pull out the roll media tray. If you must open the roll media tray, open the upper cover, raise the media release lever, then open the roll media tray.

Selecting the Media Source

When printing on roll media, with the operation panel select roll media as the media source.

- 1 Press the Online button to display “Offline”.

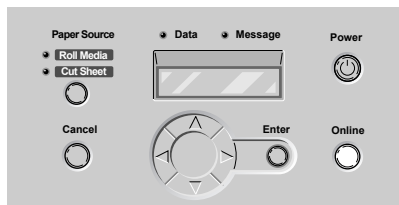

- 2** Pull the tray open lever then pull out the roll media tray.

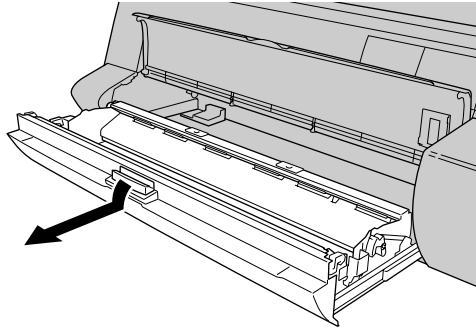

“Load Roll Media” is displayed.

- 3** If there is media remaining on the roll, rotate the roll holder in the direction of the arrow in the illustration to take up the media.

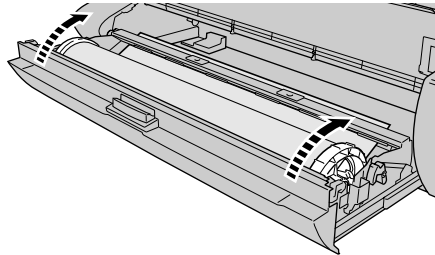

- 4** Remove the roll holder, remove the holder stopper, then remove the media.

To remove the holder stopper, pinch in the lever at the center then pull the holder stopper off. Remove any remaining paper from the roll.

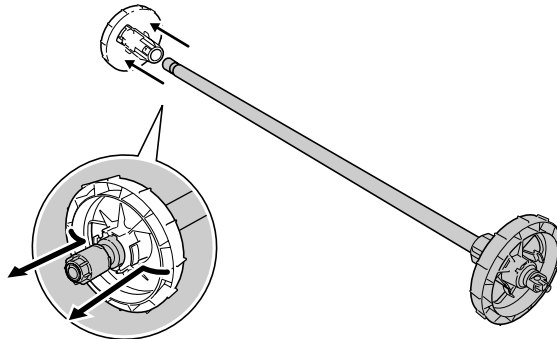



Important

- Store unused roll media in its original package. Store the package in a cool, dry location that is not exposed to direct sunlight.

- 5 Position the roll media to load as shown in the illustration, then insert the roll holder.

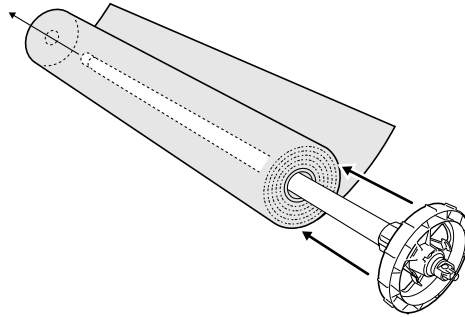

Caution

- Before setting the roll media, place it horizontally on a flat surface. Roll media is heavy so to avoid personal injury or damage to the roll, always carefully lay a roll flat on a table or other stable flat surface.



Important

- Insert the roll holder all the way into the roll media until it is tight. A gap between the roll holder and the end of the roll could cause poor feeding.

- 6 Insert the holder stopper completely into the left end of the roll holder until it stops.

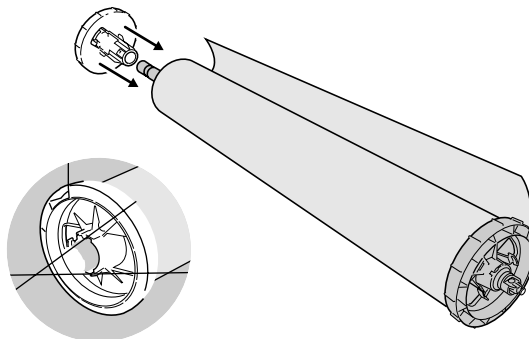

The roll media is locked in place by the roll holder.

- 7** Position the roll media as shown in the illustration, align the left and right ends of the roll holder with the grooves at either end of the roll media tray, then set the roll media in the tray.

If the roll media has unrolled, turn the roll as you set it.

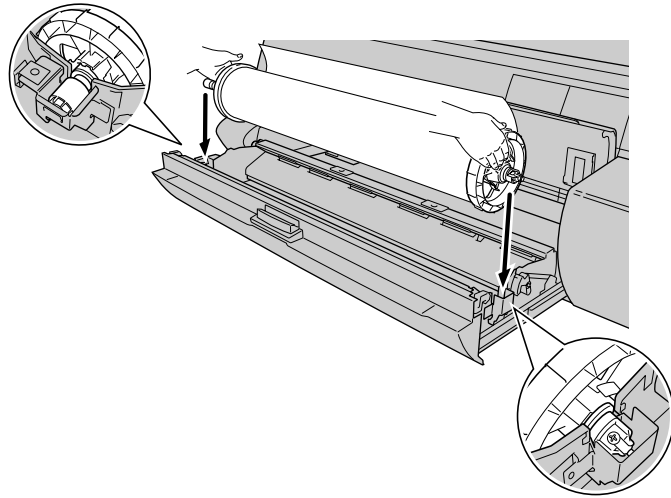

Important

- When holding the roll holder, grip it by the ring. To avoid personal injury, do not hold it by the shaft.
- While holding the roll holder, avoid touching the media anywhere other than the leading edge of the media. If you touch the surface of the media on the print side, this could cause poor printing.

- 8** Push in the roll release lever to release the paper guide.

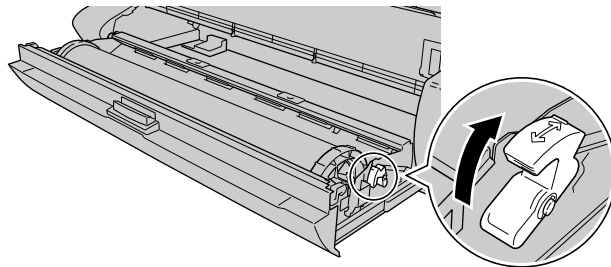

- 9** Pull up the leading edge of the roll media, and then from above pass the sheet past the paper guide as shown in the illustration.

Hold the roll media near the left and right side of the leading edge, then insert it.

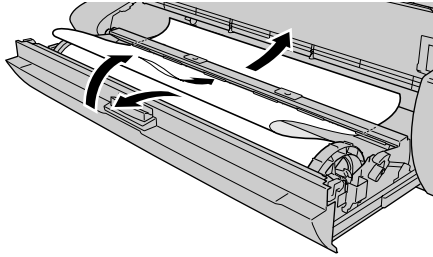

Important

- The bottom surface of the paper guide has a finish to prevent slipping. The roll media must pass over the top of the paper guide before it is inserted.

- 10** Pull out a sufficient amount of roll media to ensure that it is straight and that the left and right edges of the sheet are parallel with the sides of the tray.

Pull out enough of the leading edge of the roll sheet so you can align its left and right edges with the edge of the roll to ensure that it is straight.

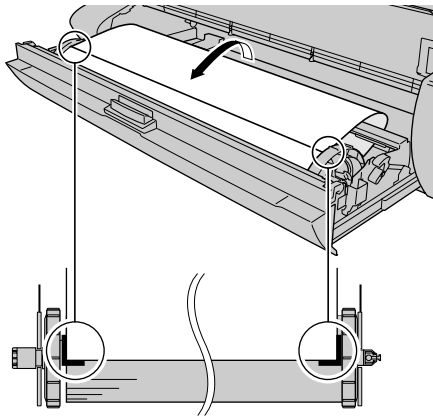

- 11** While pressing down on the center of the roll media, turn the roll holder in the direction shown in the illustration below to remove all slack from the media.

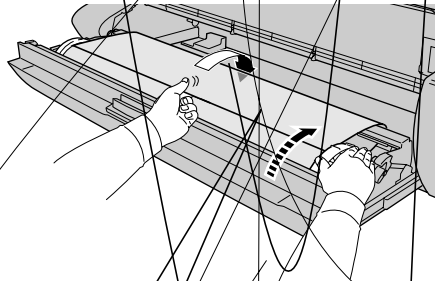

- 12** While pressing down on the roll holder, pull the roll release lever forward to lock the paper guide.

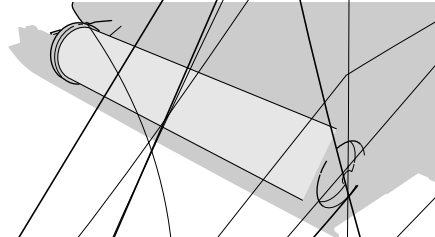

- 13** Turn the left and right ends of the roll holder in the direction indicated by the arrows to roll the leading edge of the media as far as the paper guide. Turn the roll until approximately 1~2 mm of the leading edge of the roll media is visible below the paper guide.

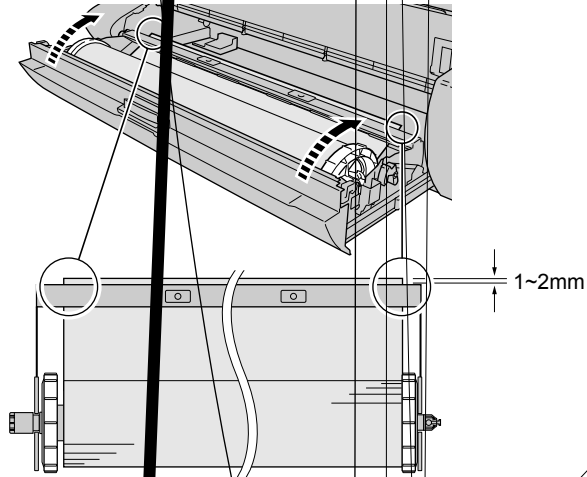

- 14** Close the roll media tray. Push in the roll media tray completely.

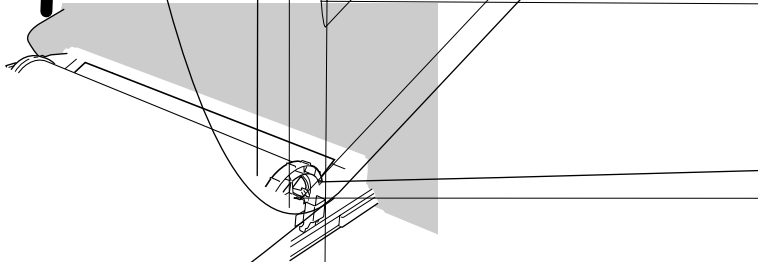

“Close Tray” is displayed.

- 15** Close the tray.

“Roll Media Type” is displayed.

- 16** Press ◀ or ▶ to select the setting for the type of roll media then press Enter.

If the same type of roll media named in the message is already loaded, then just press the Enter button.



The selection is prefixed with an equals sign (=) to indicate the roll media type that is currently selected.

The table below lists the available settings for the Roll Media Type.

For Dye Ink

Media Name	Roll Media Type Setting
Plain Paper	Plain Paper
Coated Paper	Coated Paper
Heavy Coated Paper	Heavy Coated
Glossy Paper	Glossy Paper
Photo Glossy Paper	Photo Glossy
Photo Semi-Glossy Paper	Photo Semi-Glos
Glossy Film	Glossy Film
Back Print Film	Back Print Film
Proofing Paper	Proofing Paper
—	Special 1 to 5

For Pigment Ink

Media Name	Roll Media Type Setting
Heavy Coated Paper	Heavy Coated
Photo Glossy Paper	Photo Glossy
Photo Semi-Glossy Paper	Photo Semi-Glos
Synthetic Paper (Non-Adhesive)	Syn. Paper
Synthetic Paper (Adhesive)	Adh. Syn. Paper
Back Light Film	Back Light Film
Flame-Resistant Cloth	Flame-Res. Cloth
—	Special 1 to 5

Roll media starts to feed as soon as the type of media is selected.

After a few seconds, “Online” is displayed and the printer is ready to print.



Important

- You must make the appropriate selection for the “Roll Media Type” setting. If the “Roll Media Type” selection does not match the roll media loaded in the printer, execute the procedures of “Selecting the Roll Media Type”. (→ P.2-18)

- While roll media is loaded in the printer, avoid opening and closing the roll media tray. Opening and closing the tray causes the printer to cut the leading edge of the roll media and consume paper.
- You should remove each sheet output to the output stacker, one at a time.



Note

- Before shipping a dye ink printer, the Media Type is set for “Plain Paper”.
- Before shipping a pigment ink printer, the Media Type is set for “Heavy Coated”.
- It is recommended that the special settings (1 to 5) be used when smudges and blots appear on the print density is too light while printing on one of the media types listed above. The Special settings determine in 5 steps the amount of ink used on the surface of the media. The higher the number in the range of 1 to 5, the greater the amount of ink used. The setting may require testing and adjustment, depending on the media in use and the content of the image.
- The media size is detected automatically, therefore no setting for the size is required.
- In order to align the leading edge correctly when the roll media is replaced with a new one, the paper is fed approximately 100 mm (4 in.) then cut.

Selecting the Roll Media Type

After loading roll media in the printer, you must select the correct Roll Media Type setting on the operation panel. If the Roll Media Type setting does not match the roll media loaded in the printer, the print job cannot execute correctly from the computer. As soon as the roll media is set in the roll media tray, “Roll Media Type” is displayed on the operation panel. If the Roll Media Type selection is not correct for the roll media in the printer, follow the procedure below to make the correct selection.

- 1 Press the Online button twice to display “MAIN MENU”.

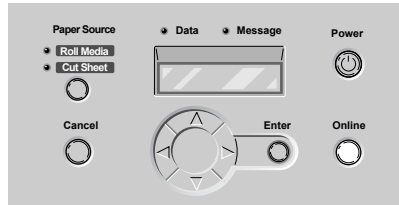

- 2 Press ◀ or ▶ to select “Roll Media Type” then press ▼.



- 3 Press ◀ or ▶ to select the setting for the type of roll media then press Enter.



The selection is prefixed with an equals sign (=) to indicate the roll media type that is selected.



Important

- The amount of feed is finely adjusted for each type of media in order to achieve the best quality printing. Therefore, the size of the image and margins change slightly for each type of media.
- When you switch the type of media for printing, you must also adjust the amount of media feed for the loaded media.

Loading Cut Sheets

This is the general procedure for loading cut sheets.

- Remove all printed roll media or cut sheets from the tray.
- On the operation panel, select the cut sheet source. (→ P.2-19)
- Load the cut sheet on the tray. (→ P.2-21)
- On the operation panel, select the Cut Sheet Type. (→ P.2-24)
- Adjust the amount of media feed. (→ P.7-38)
- Start the print job on the computer. (→ P.3-2, P.4-2)



Important

- Store unused cut sheets in the original package. Store the package in a cool, dry location that is not exposed to direct sunlight.



Note

- Simply pressing Paper Source on the operation panel alternately selects Roll Media or Cut Sheet. If you select Cut Sheet by pressing Paper Source, the roll media source automatically moves to the print standby position so the cut sheet can be set for printing. After the cut sheet is printed, the printer automatically returns to the Roll Media selection for printing.

Selecting the Cut Sheet Source

Use the Paper Source button on the operation panel to set the printer for printing on cut sheets.

- 1 Press the Online button to display “Offline”.

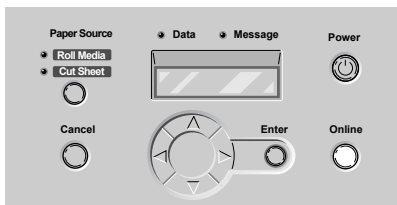

Loading Cut Sheets

Follow the procedure below to load a cut sheet in the tray. First, remove any paper or other output in the tray.

Note

- Before changing to a larger media size, open the upper cover and clean the interior of the printer to ensure that the entire platen is clean. (→ P.6-11)
- For more details about the type of cut sheets that can be loaded in the printer, refer to “Print Media That Can Be Used”. (→ P.2-2)

1 Open the upper cover.

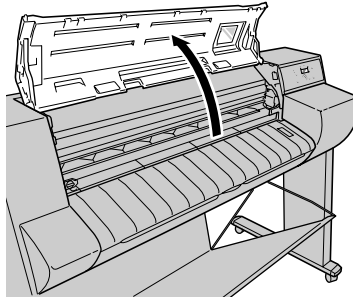

Important

- To avoid soiling your hands or damaging the printer, never touch any part inside the printer unless instructed to do so.

2 Raise the paper release lever.

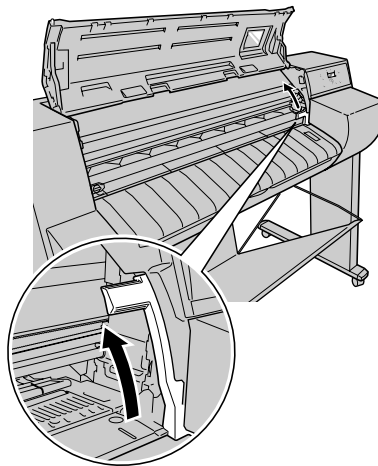

- 3** With the front side of the cut sheet facing up, insert it parallel into the paper restraint, so the cut sheet is aligned with the right guide (a) and the inner guide (b).

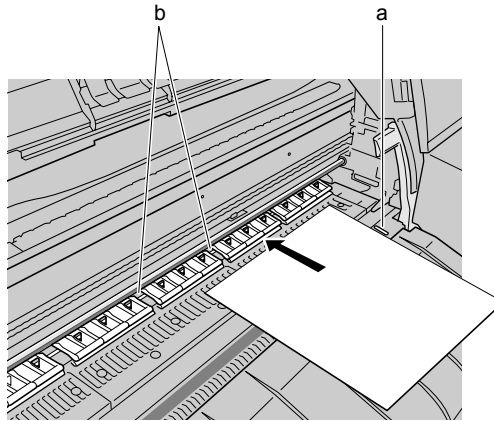

When the cut sheet is inserted, the printer grabs it and holds it on the platen.

 **Important**

- Set the cut sheet so it is straight and aligned with the right side of the platen. If the cut sheet is skewed, this will cause an error. If an error occurs, remove the cut sheet and set it straight again.

 **Note**

- Suction through holes on the platen maintain the position of the paper on the platen. Depending on the position of the media on the platen, you may hear a slight whistling sound, caused by these suction holes. This is not abnormal.
- If you are concerned about the sound caused by the suction holes, adjust the guide on the left and right to within 1 mm of the edge of the media.

- 4** Lower the paper release lever.

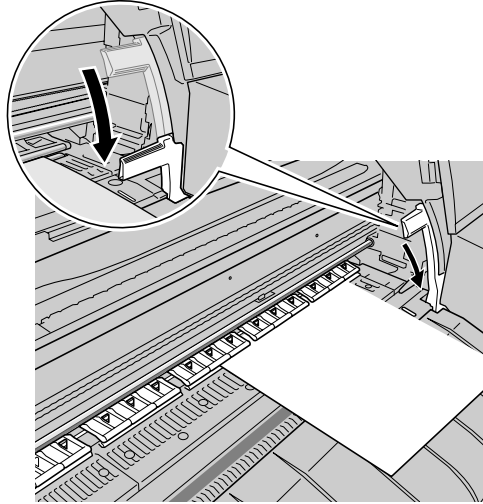

- 5** Close the upper cover.

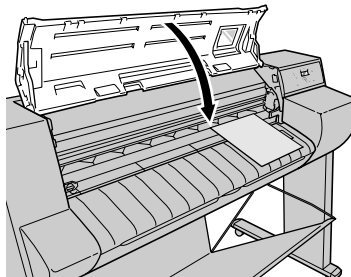

“Cut Sheet Type” is displayed.

6 Press ◀ or ▶ to select the type of cut sheet, then press Enter.

If the same type of cut sheet named in the message is already loaded, then just press the Enter button.



The cut sheet starts to feed.

If the printer detects no skew and there is no problem, then the printer enters the print standby mode.

The table below lists the possible settings for the cut sheet type.

For Dye Ink

Media Name	Roll Media Type Setting
Plain Paper	Plain Paper
Coated Paper	Coated Paper
Heavy Coated Paper	Heavy Coated
Glossy Paper	Glossy Paper
Photo Glossy Paper	Photo Glossy
Photo Semi-Glossy Paper	Photo Semi-Glos
Glossy Film	Glossy Film
Back Print Film	Back Print Film
Proofing Paper	Proofing Paper
—	Special 1 to 5

For Pigment Ink

Media Name	Roll Media Type Setting
Heavy Coated Paper	Heavy Coated
Photo Glossy Paper	Photo Glossy
Photo Semi-Glossy Paper	Photo Semi-Glos
Synthetic Paper (Non-Adhesive)	Syn. Paper
Synthetic Paper (Adhesive)	Adh. Syn. Paper
Back Light Film	Back Light Film
Flame-Resistant Cloth	Flame-Res.Cloth
—	Special 1 to 5



Important

- A skew error occurs if the cut sheet is not straight. In this case, repeat the above procedure from Step 1 to set the cut sheet.
- You must set the correct type of cut sheet. If the set cut sheet does not match the Cut Sheet Type setting, make the correct setting.
(→ “Select the Cut Sheet Type”, P.2-26)
- You should remove each sheet output to the output stacker, one at a time.



Note

- Before shipping a dye ink printer, the Media Type is set for “Plain Paper”.
- Before shipping a pigment ink printer, the Media Type is set for “Heavy Coated”.
- It is recommended that the special settings (1 to 5) be used when smudges and blots appear on the print density is too light while printing on one of the media types listed above. The Special settings determine in 5 steps the amount of ink used on the surface of the media. The higher the number in the range of 1 to 5, the greater the amount of ink used. The setting may require testing and adjustment, depending on the media in use and the content of the image.
- The media size is detected automatically, therefore no setting for the size is required.

Select the Cut Sheet Type

Whenever a cut sheet is set, the Cut Sheet Type setting must be set. This setting must be done correctly in order to execute the print job.

- 1 Press the Online button twice to display “MAIN MENU”.

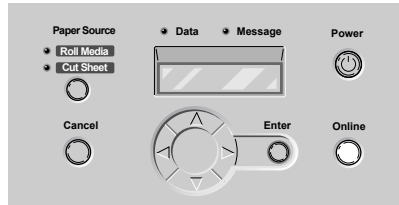

- 2 Press ◀ or ▶ to select “Cut Sheet Type” then press ▼.



- 3 Press ◀ or ▶ to select the type of cut sheet then press Enter.

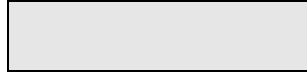

The selection is prefixed with an equals sign (=) to indicate the cut sheet type that is selected.



Important

- The amount of feed is finely adjusted for each type of media in order to achieve the best quality printing. Therefore, the size of the image and margins change slightly for each type of media.
- When you switch the type of media for printing, you must also adjust the amount of media feed for the loaded media. (→ Chapter 7, “Adjusting Amount of Media Feed”, P.7-38)

High Quality Printing on Film

By adjusting the height of the printhead before printing on glossy film or other film base media, you can achieve superior quality image printing. When you want to increase the precision of printing, or if you need eliminate coarse texture in the print, follow the procedure below.

- Adjust the height of the printhead. (→ P.2-27)
- Select the correct setting for the media type. (→ P.2-8, P.2-19)
- Align the printhead. (→ P.2-30)
- Execute the print job. (→ Chapter 3, “Printing from Windows”, Chapter 4, “Printing from a Macintosh”)
- After completing the special print job, return the printhead height to its original setting and re-align the printhead. (→ P.2-30)

Important

- When adjusting the height of the printhead, you must also align the printhead. Otherwise, the print job will not achieve the best results.
- When printing on glossy paper, or any other glossy base media that wrinkles easily, to avoid damaging the printhead, never print with the printhead in the down position.

Adjusting Printhead Height

- 1 Press the Online button to display “Offline”.

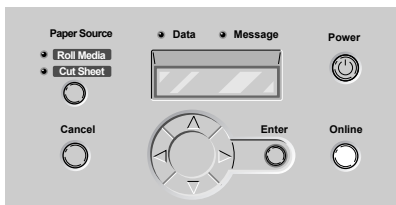

- 2** Press and hold ◀ for more than 1 second.

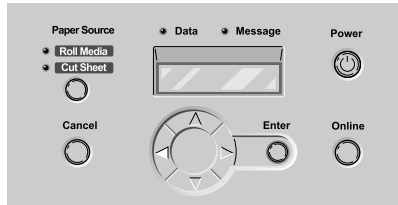

The carriage moves to the center.

- 3** Open the upper cover.

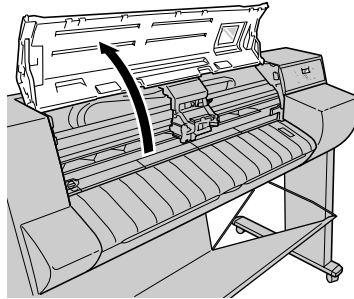

Important

- To avoid soiling your hands or damaging the printer, never touch any part inside the printer unless instructed to do so.
- If the printhead height adjustment lever is dirty, before continuing with this procedure, wring out a damp cloth and use it to clean the printhead height adjustment lever.

4 Adjust the height of the printhead with the printhead height adjustment lever.

For printing on film-base media, set the lever to the down position (a).

For printing on paper, set the lever to the center(standard) position (b).

For printing on thick paper, or on paper that wrinkles easily, set the lever to the up position (c).

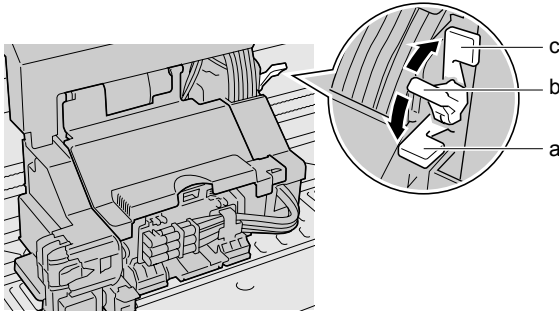

5 Close the upper cover.

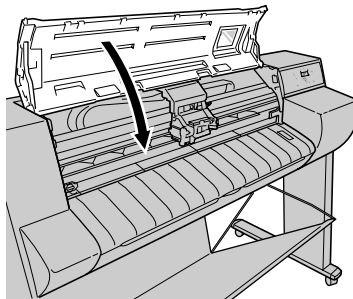

The carriage returns to the home position, the Online lamp lights, and the printer is ready to print.

Aligning the Printhead

After adjusting the height of the printhead, use the operation panel to execute “Print Pattern A”, then adjust the printhead alignment. (→ “Aligning the Printhead” P.7-35)

Re-adjusting Printhead Height

After the print job is finished, especially before starting the next print with another type of media, you must do the procedure to reset the printhead height adjustment lever to the center(standard) position. (→ “Adjusting Printhead Height” P.2-27)

After re-adjusting the printhead height position, you should once again use the operation panel to align the printhead. (→ “Aligning the Printhead” P.7-35)

Using the Media Take-up Unit

When the optional Media Take-up Unit is installed, the media take-up unit can be used to take up printed roll media as it is output from the printer. This is convenient for very long, continuous print jobs on roll media. Here is a summary of the general procedure for using the Media Take-up Unit.

- Load the roll media in the printer. (→ P.2-9)
- Use the operation panel to select “Enable” for the “Take-up Reel” item in the MAIN MENU. (→ P.2-32)
- Install the Media Take-up Unit. (→ P.2-33)
- Execute the print job. (→ Chapter 3 “Printing from Windows”, Chapter 4 “Printing from a Macintosh”)
- Remove the printed media from the take-up reel of the Media Take-up Unit. (→ P.2-39)
- Use the operation panel to select “Disable” for the “Take-up Reel” item in the MAIN MENU. (→ P.2-43)



Important

- When using the Media Take-up Unit, do not block the sensor or lay anything on sensor to ensure that the unit operates correctly.
- When using the Media Take-up Unit, the auto cut feature never cuts the media, regardless of the Auto Cut setting on the MAIN MENU. However, if the Auto Cut setting in the printer driver is switched on, the media will be cut. Be sure to check this setting off before starting the print job.
- The Media Take-up Unit cannot be used with cut sheets.
- Plain paper, Glossy Film, Back Print Film, and synthetic paper (non-adhesive) roll paper cannot be used with the Media Take-up unit.
- With some print media, the hue of some colors may change slightly when the ink on the surface of the media has dried completely. Before you confirm the final hues or handle the media for display, make sure that the ink has dried thoroughly.
- When printing on thinly coated media or thin, weak media with a large amount of ink in a location where the humidity is high, the media may be difficult to take up cleanly without smearing. In such a case, improve the environmental situation such as relocation or climate control, or set the ink drying time to insure that the printed media is dry when it is taken up.

Settings for Using the Media Take-up Unit

- 1 Press the Online button twice to display “MAIN MENU”.

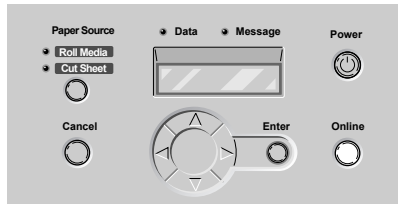

- 2 Press ◀ or ▶ to display “Take-up Reel” then press ▼.



- 3 Press ◀ or ▶ to display “Enable” then press Enter.

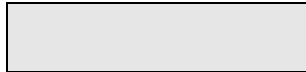

The selection is prefixed with an equals sign (=), and the Media Take-up Unit is ready to use.

Loading Roll Media

- 1 On the Media Take-up Unit, set the take-up mode switch to “Manual”.

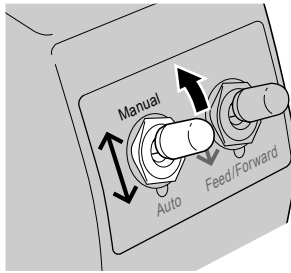

- 2 If the output stacker is installed, remove it from the stand.

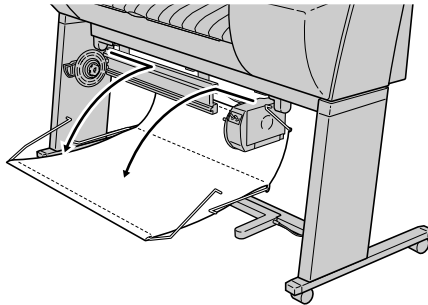

Store the output stacker where it will not interfere with the sensors.

- 3 While pressing down on the slide holder release lever (a), move the slide holder to the left.

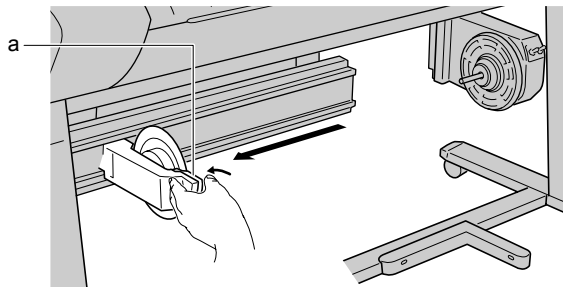

- 4** Insert the media core onto the center hubs of the take-up holders.

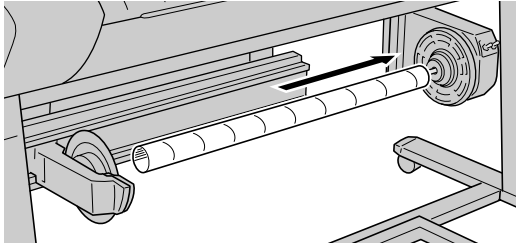

- 5** With your left hand, push the slide holder toward the left end of the media core, and continue to push firmly until you hear the hub of the slide holder catch and lock into the core media.

Push until the hubs of the left and right ends of the holder (a) are inserted completely into the media core.

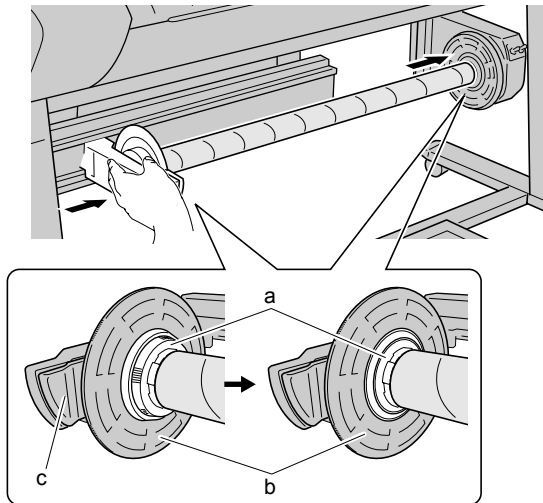

Important

- To ensure that the slide holder release lever (c) remains completely locked, never grasp the slide holder lever when you press on the slide holder. If the slide holder lever is only partially locked, this could interfere with the operation of the Media Take-up Unit.
- After pressing in firmly on the slide holder, check the core to make sure that it does not shake. Hold the media core and move it left and right. If there is a difference in the level of side (a) and side (b), remove the media core and set it again.

- 6** Press the Online button twice to display “MAIN MENU”.

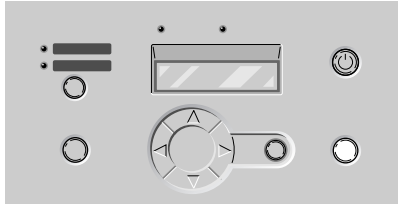

- 7** Press ◀ or ▶ to select “Auto Feed” then press ▼.

- 8** Press ◀ or ▶ to select “Yes” then press Enter.

The selection is prefixed with an equals sign (=) to indicate the amount selected for feed to the Media Take-up Unit.

- 9** Holding the leading edge of the roll at its center, align it with the right edge of the take-up holder, then with the sheet extended, tape the center of the sheet to the center of the media core.

- 10** Taking care not to loosen the roll media, tape the left and right edges of the sheet to the media core.

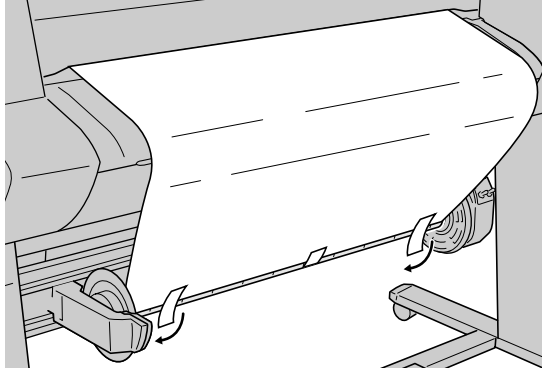

- 11** Press ▼ to feed some slack into the roll media.

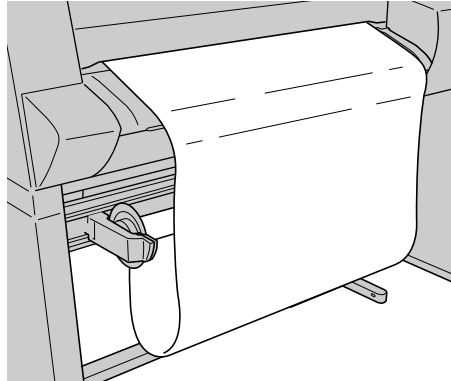

- 12** On the Media Take-up Unit, press and hold down the take-up switch until the slack disappears.

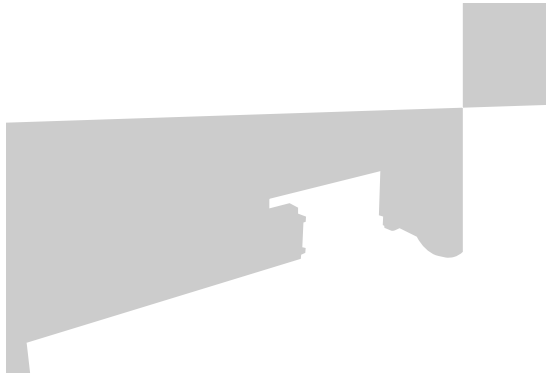
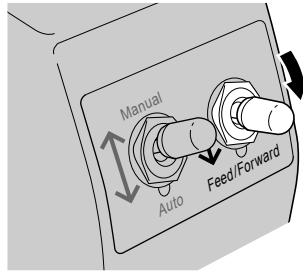

Important

- Allow the media core to turn for more than two rotations. If the media is not taken up by at least two rotations, repeat Steps 11 and 12.

- 13** Press ▼ to feed some slack into the roll media.

14 Install the correct weight roll (a, b, c, d) and weight joint (e) for the width of the roll media.

The combination of the weight rolls is as follows. A color label is attached to each weight roll.

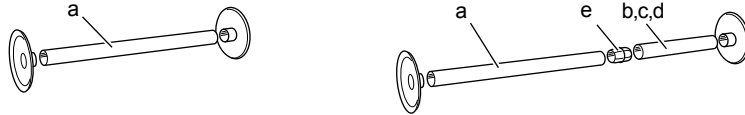

Corresponding Roll Media Size	Weight Roll to Use
(24"/610 mm)	Black (a)
(36"/914 mm)	Black (a) + Blue (b)
(42"/1067 mm)	Black (a) + Red (c)
(44"/1118 mm)	Black (a) + Yellow (d)

 **Note**

- The weight roll (b, c, d) cannot be used other than the combinations above.

15 Gently set the weight roll on the roll media slack.

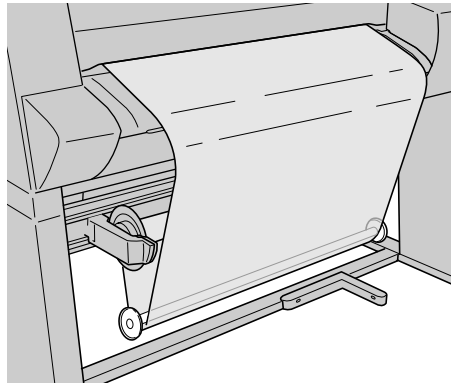

 **Important**

- You must install the weight roll to avoid poor performance of the media take-up unit.
- When positioning the weight roll, be careful not to touch the media core to avoid turning the core and moving the left and right edges of the sheet out of position on the media core.

- 16 Press the Online button to display “Online”.

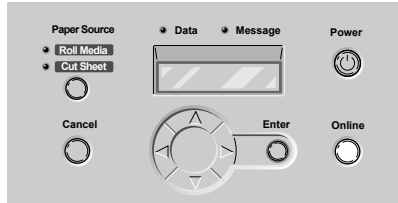

- 17 On the Media Take-up Unit, set the take-up mode switch to Auto.

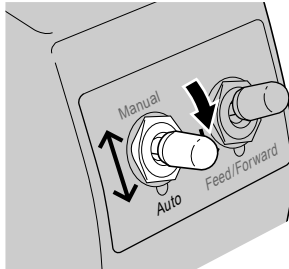

This completes the installation of the Media Take-up Unit. You can now execute print jobs from the computer.

Removing Printed Media from the Media Take-up Unit

When the print job is finished, follow the procedures below to remove the printed media from the Media Take-up Unit.

- 1 Press the Online button to display “Offline”.

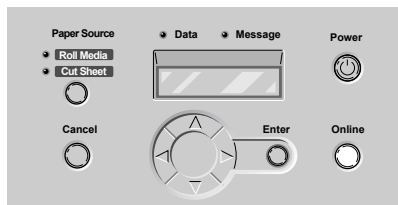

- 2** Press ▼ to feed the roll media by a small amount.

If you want to save the roll media that you are about to remove, feed the roll media about one full turn of the roll.

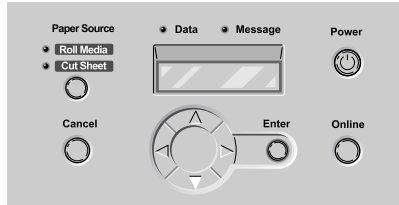

- 3** On the Media Take-up Unit, set the take-up mode switch to "Manual".

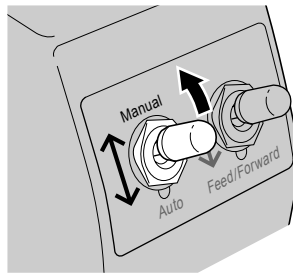

- 4** Remove the weight roll from inside the roll media.

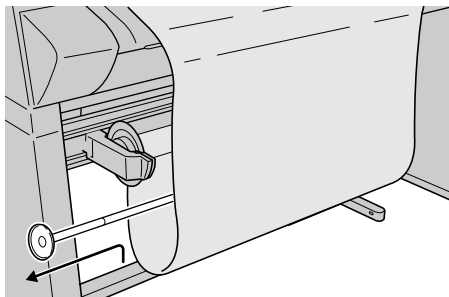

- 5 Press the Online button twice to display “MAIN MENU”.

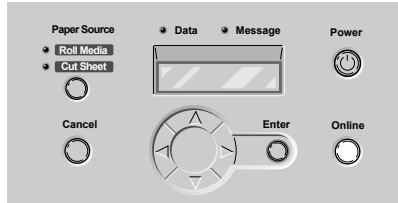

- 6 Press ◀ or ▶ to display “Force Cutting” then press ▼.



- 7 While holding the trailing edge of the printed media, press ◀ or ▶ to display “Yes”, then press Enter.



The roll media is cut.



Important

- You must hold the trailing edge of the printed sheet while it is being cut. If the sheet is cut without holding it, the printed sheet will fall on the floor and the printed side may become soiled.

ed sheet, on the Media
h to take up the media onto

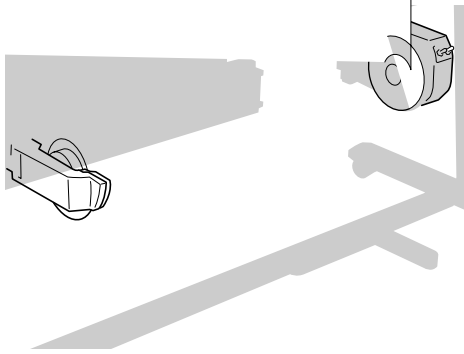

Tape the edge of the roll if required.



Important

- Be careful not to damage the print surface of the media.

- 9** While supporting the printed media with your hand, press the slide holder release lever to the left, then remove the printed roll media.

- 10** If the output stacker was in use, re-attach it to the stand.

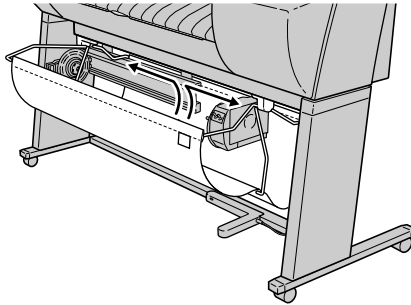

Disabling the Media Take-up Unit

- 1** Press the Online button twice to display “MAIN MENU”.

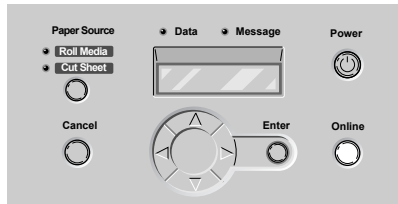

- 2** Press ◀ or ▶ to display “Take-up Reel” then press ▼.



- 3** Press ◀ or ▶ to display “Disable” then press Enter.



The selection is prefixed with an equals sign (=) to indicate that the Media Take-up Unit can no longer be used.

3

Printing from Windows

This chapter describes the basic procedures for printing from Windows.

Printing

To print a job from a Windows software application, use the Print command in the File menu.



Important

- Before executing a print job with this printer, close all other software applications. If another application is processing data during printing, this could cause loss of data during data transfer, or cause the printer to temporarily pause during printing, resulting in poor print quality.



Note

- For more details about the printer driver, refer to the printer driver online Help. (→P.3-5)

Print Procedure

- 1 In the software application, select Print from the File menu.

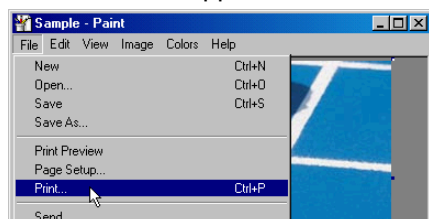

The Print window opens.

- 2 Make sure the name of the printer is displayed in the Name box, perform the settings for the “Page range” and “Copies” group, then click the OK button.

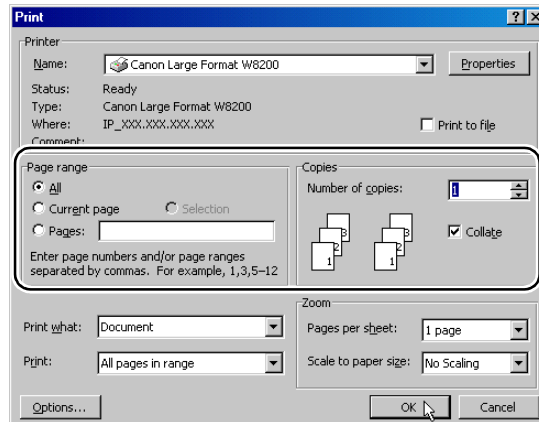

The print job starts.



Important

- You should remove each sheet output to the output stacker, one at a time.



Note

- Click the Properties button if you want to select the Media Type, paper feed method, or adjust quality and Color Settings, or perform other settings.
- Before starting a print job on a very long sheet, or a job where many copies are required, be sure to check the ink supply before starting the job. If ink runs out during the print job, you may lose the print job data. To check the ink supply level, in the Windows drive click the Main tab, click the Status Monitor button, then view the Printer Information.

However, if you reinstall an ink tank that is nearly out of ink and use it this could cause the print quality to deteriorate.

Never try to reinstall an ink tank once you see it marked with an exclamation mark (!) symbol in the ink level display.

- This cannot be displayed when the Status Monitor is not installed. Be sure to install the Status Monitor beforehand. (→ Setup Guide, Chapter 3, Installing the Software)

Canceling a Print Job

Follow this procedure to cancel a print job.

- 1** In the Printers folder, double-click the icon for the printer.
- 2** Click the name of the job that you want to cancel, click Printer in the menu bar and select Cancel All Documents.

The print job is deleted.

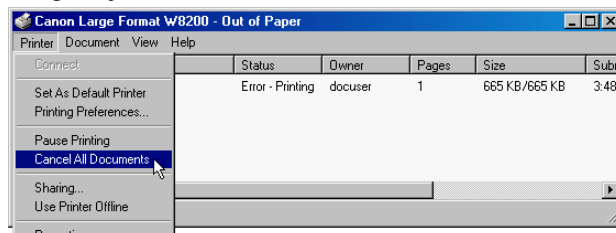

- 3** If the Online lamp on the printer operation panel is flashing, indicating that the print job is still processing, press Online. When "Pause" is displayed, press Cancel for over 0.5 seconds.

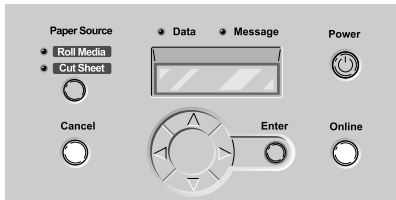

The print job in progress is canceled.

- 4** If the Data lamp goes off and you cannot cancel the print job, then use GARO Status Monitor to cancel the print job.
- 5** If the GARO Status Monitor is not installed, hold down the Power button for 1 second or more until the Online lamp goes off and release it, then switch the printer power off and on.

If you switch off the printer, all the print jobs received by the printer and currently in progress are erased completely. You will need to restart any job you need to print.

Viewing Online Help

Online Help is available to explain the functions and items of the printer driver.

Opening Online Help

- 1 In the Printer Properties window, click the Help button.

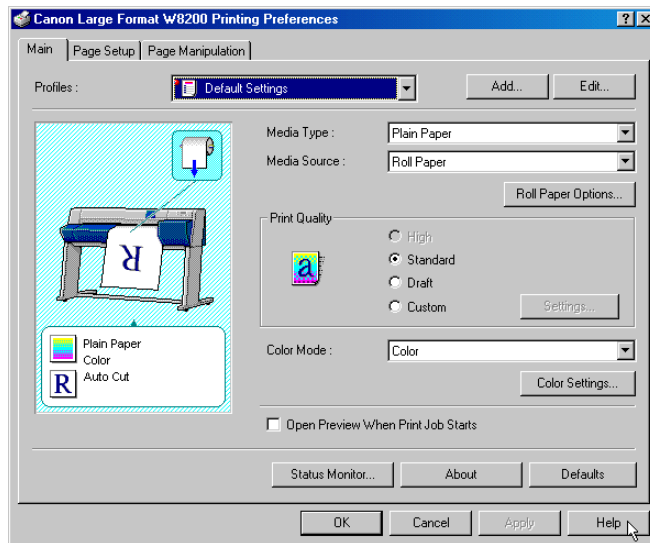

The Help window opens.

Note

- For more details about how to use the Help window, please refer to your operating system manual.

4

Printing from a Macintosh

This chapter describes the basic procedures for printing from a Macintosh.

Printing

To print a job from a Macintosh software application, first select the printer then use the Print command in the File menu.



Important

- Before executing a print job with this printer, close all other software applications. If another application is processing data during printing, this could cause loss of data during data transfer, or cause the printer to temporarily pause during printing, resulting in poor print quality.



Note

- For more details about the printer driver, refer to the printer driver Help. (→ P.4-13)

Selecting the Printer

■ Mac OS 8.6/9.x

With Mac OS 8.6/9.x use the Chooser to select the printer. However, if the printer is switched off, or if the cable is disconnected, the name of the printer will not appear in the list. Be sure to check the status of the printer before starting a print job.



Note

- Occasionally you may not be able to share use of the printer when it is connected via USB. If this case, connect to the USB or IEEE1394 board directly. If the printer is not shared, print from a Windows computer.

1 From the Apple menu, select Chooser.

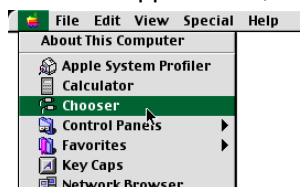

- 2** Click the GARO Printer Driver icon in the list on the left, then in the right list under Destination select the name of the selected printer.
- If the printer is connected to a network, make sure that the Active button for AppleTalk is clicked on.

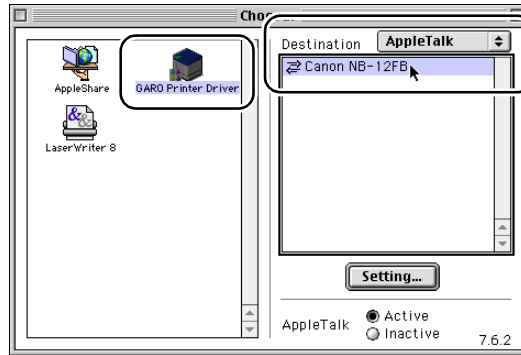

- 3** Close the Chooser window and click the OK button in the message window.

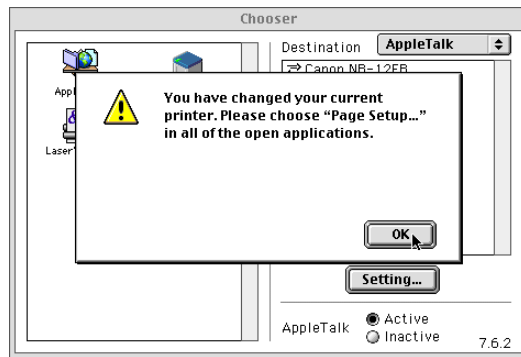

This completes the selection of the printer.

■ Mac OS X

With Mac OS X use Print Center to select the printer. However, if the printer is switched off, or if the cable is disconnected, the name of the printer will not appear in the list. Be sure to check the status of the printer before starting a print job.

An example using Mac OS X Ver. 10.2 is described here. The appearance and name of the icon is slightly different using Ver. 10.1.

- 1 Select the Finder then select Applications from the Go menu.

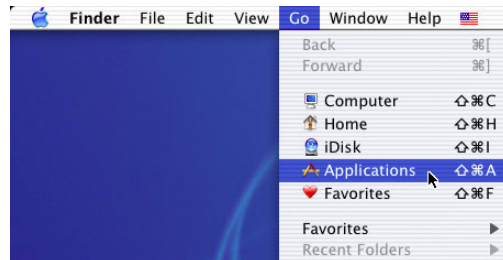

- 2 Open the Utilities folder and open Print Center.



- 3 If the name of the printer is not in the Printer List, click the Add Printer icon.

If the name of the printer is in the list, go to Step 5.

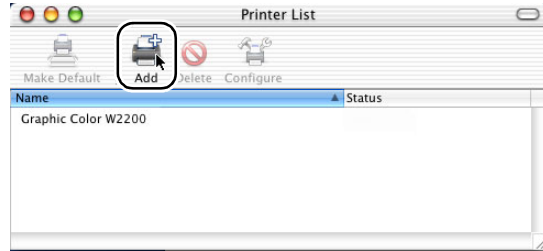

- 4 In the new connection menu connect the connection destination for the printer, select the name of the printer from the list, then click the Add button.

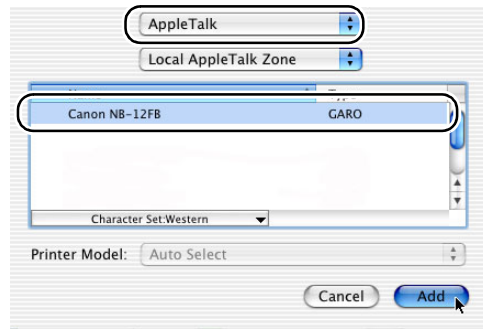

Note

- If the name of the printer is not displayed, check the printer connection cable, and make sure that the printer and network device are both switched on.

- 5 If you want to set the printer as the default, select the name of the printer in the Printer List, then select Make Default from the Printers menu.

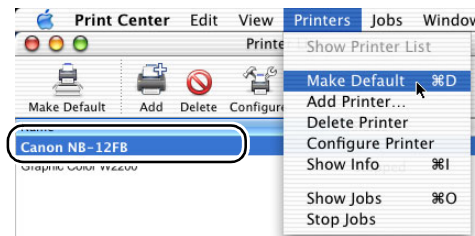

Note

- The printer can now be selected for the Print item in the Printer dialog box.

Print Procedure

- 1 In the software application, select Print from the File menu.

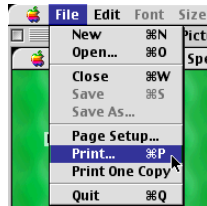

The Print window opens.

- 2 Check the Printer box and make sure that the name of the printer is displayed. On the Main panel select the settings for the Page, number of Copies, Media Type, Media Source, Print Quality, and other settings.

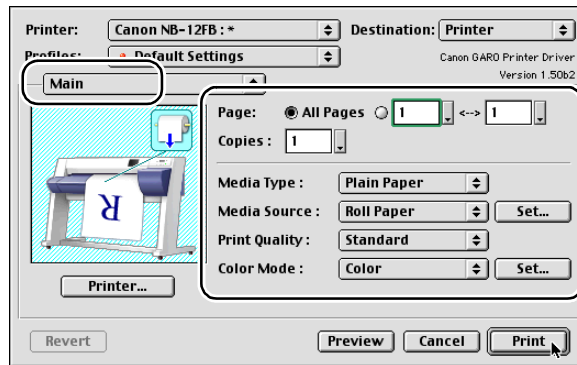

If you are using Mac OS X, set the Copies&Pages panel and the Main panel.

- 3 Click the Print button.

The print job starts.



Important

- You should remove each sheet output to the output stacker, one at a time.



Note

- Before starting a print job on a very long sheet, or a job where many copies are required, be sure to check the ink supply before starting the job. If ink runs out during the print job, you may lose the print job data. To check the ink supply level, in the Mac drive click the Main menu, click the Printer Information button, then view the Printer Information.

However, if you reinstall an ink tank that is nearly out of ink and use it this could cause the print quality to deteriorate. Never try to reinstall an ink tank once you see it marked with an exclamation mark (!) symbol in the ink level display.

Canceling a Print Job

The procedure to cancel a print job is different, depending on whether the job is printing in the background or the foreground.



Note

- With Mac OS X all print jobs execute in the background; print jobs do not execute in the foreground.

Canceling a Background Print Job

With print jobs are printing in the background, you can check their status or cancel them at any time. Follow the procedures below to cancel a print job.

■ Mac OS 8.6/9.x

- 1** In the GARO Printer Extra folder installed on the hard disk, click the GARO Printmonitor icon.
- 2** Select the print job to cancel, then click the Printing Paused button.

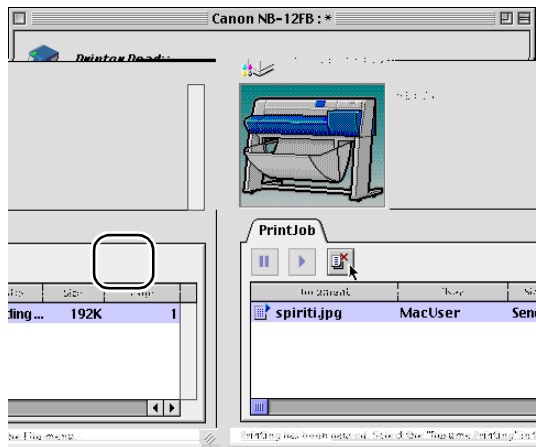

The print queue halts and shifts from the Sending status to the Send status. A red mark is displayed on the right while the print queue is halted.

In the Send status select the Job icon marked with the red dot, click the Printing Paused button to delete the print job, then go to Step 4.

- 3 With the Job selected for deletion, click the **Printing Paused** button again.

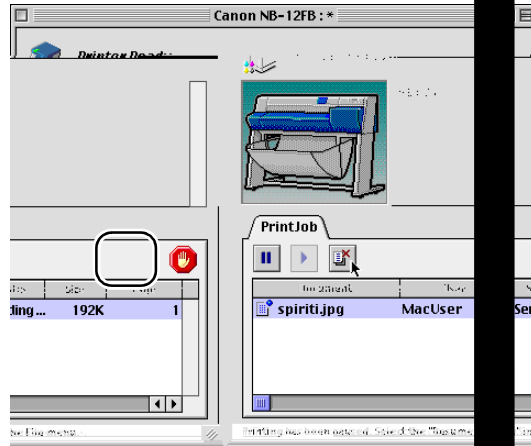

The print job is deleted.

- 4 Select **Resume Printing** from the **File** menu.

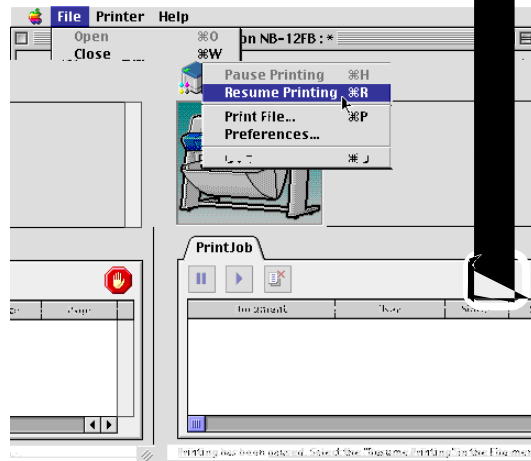

The printer re-enters print mode and is ready for operation.



Important

- If the print job data has already been sent to the printer, the print job cannot be canceled. After canceling a print job, you should always select **Resume Printing**. With the print queue halted (the red mark will be displayed), you cannot print.

- 5 If the Online lamp on the printer operation panel is flashing, indicating that the job is still in progress, press and hold down the Online button to display “Pause” on the operation panel, then press Cancel for over 0.5 seconds.

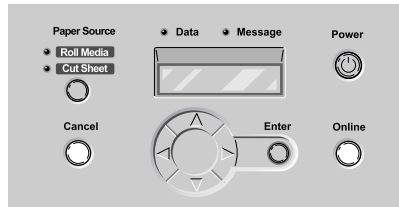

The print job in progress is canceled.

- 6 If the Data lamp goes off and you cannot cancel the print job, hold down the Power button for 1 second or more until the Online lamp goes off and release it, then after the printer switches off, switch it on again.

If you switch off the printer, all the print jobs received by the printer and currently in progress are erased completely. You will need to restart any job you need to print.

■ Mac OS X

An example using Mac OS X Ver. 10.2 is described here. The appearance and name of the icon is slightly different using Ver. 10.1.

- 1 Select the Finder then select Applications from the Go menu.

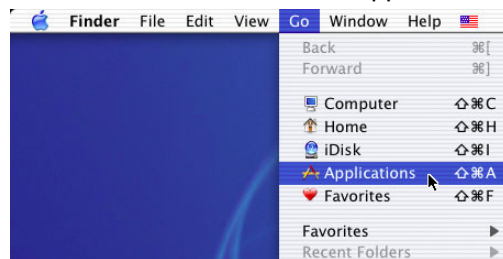

2 Open the Utilities folder and open Print Center.

3 Select the name of the printer from the Printer List, then select Show Jobs from the Printers menu.



Important

- After the print data has been sent to the printer, the print job cannot be canceled. When you want to cancel a print job that remains in the printer, do the GARO Printmonitor job cancel procedure. To open the GARO Printmonitor, in the Print Center of the Printer menu select Printer Settings. Select the print job to cancel, then click the Print Cancel button to cancel the print job.

- 5** If the Online lamp on the printer operation panel is flashing, indicating that the job is still in progress, press and hold down the Online button to display “Pause” on the operation panel, then press the Cancel button for over 0.5 second.

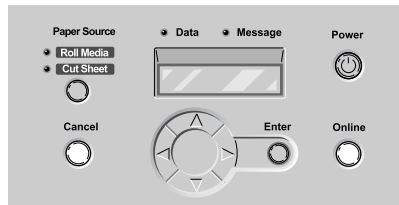

The print job in progress is canceled.

- 6** If the Data lamp goes off and you cannot cancel the print job, hold down the Power button for 1 second or more until the Online lamp goes off and release it, then after the printer switches off, switch it on again.

If you switch off the printer, all the print jobs received by the printer and currently in progress are erased completely. You will need to restart any job you need to print.

Canceling a Foreground Print Job

Follow the procedure below to cancel a print job in the foreground. When you cancel a print job in the foreground, the print-in-progress dialog box opens.

- 1** When the print-in-progress dialog box opens, press and hold down the Command key and press the period (.) key.

The print job is canceled.

- 2** If the Online lamp on the printer operation panel is flashing, indicating that the job is still in progress, press and hold down the Online button to display “Pause” on the operation panel, then press the Cancel button for over 0.5 second.

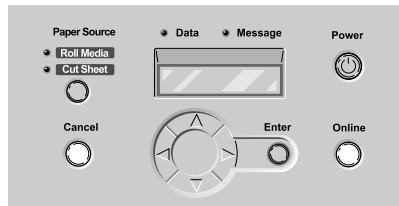

The print job in progress is canceled.

- 3** If the Data lamp goes off and you cannot cancel the print job, hold down the Power button for 1 second or more until the Online lamp goes off and release it, then after the printer switches off, switch it on again.

If you switch off the printer, all the print jobs received by the printer and currently in progress are erased completely. You will need to restart any job you need to print.

Viewing Help

The Help file is available on the User software CD-ROM in a PDF file to describe the functions and items of the printer driver.

Opening Help

- 1 Mount the User Software CD-ROM into the CD-ROM drive, then open the PDF icon.

For Mac OS 8.x/9.x open the W8200DRV89_Us file in the OS89 folder.

For Mac OS X open the W8200DRVx_Us file in the OSX folder.



Note

- Adobe Acrobat Reader is required to view the Help.
- For details about how to use Adobe Acrobat Reader, please refer to the Adobe Acrobat Reader manual.
- You can copy the Help file to the hard disk. This will allow you to view the Help at any time without mounting the User Software CD-ROM.

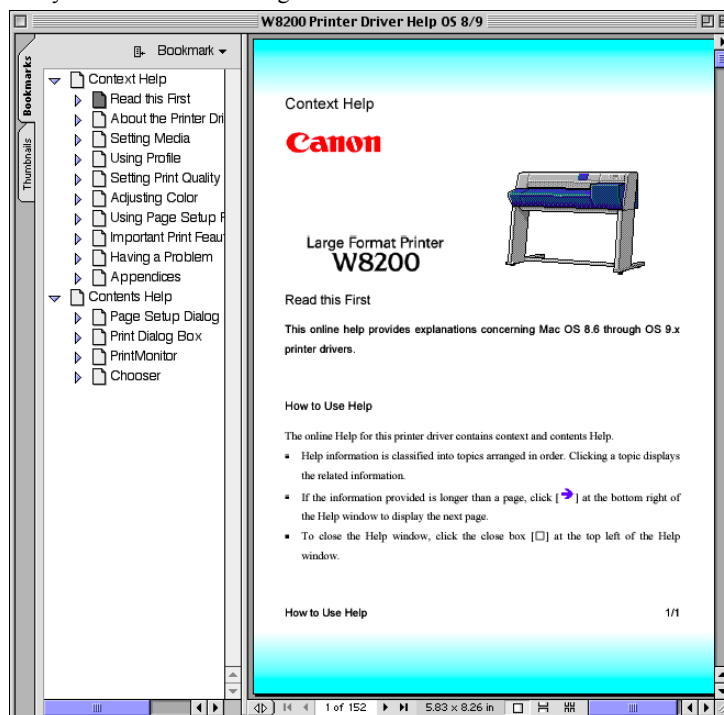

5

Using the Operation Panel

This chapter describes how to use the printer operation panel buttons and functions.

What's On the Operation Panel?

On the printer operation panel there is a display (a), nine buttons (b), and five lamps (c). The operation panel is used to indicate the current status of the printer, display messages and settings, and perform menu settings.

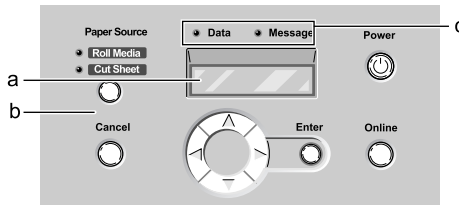

Reading the Display

The display indicates the current status of the printer.

■ Standby

Dye ink printer



Pigment ink printer



Line 1:

The first line of the display indicates the current status of the printer.

Line 2:

Dye or Pigment is displayed. This indicates the dye ink printer or pigment printer, respectively.

■ Print Job Processing



“Printing” displayed in the first line tells you that the printer is operating.

■ Menu Display



Line 1:

Displays the name of the menu or submenu.

Line 2:

Displays an item for selection. A down arrow (▼) on the right indicates that items are available for selection at the next level below.

■ Current Selection



Line 1:

Displays the name of the submenu.

Line 2:

Displays the item or value of the setting. A setting prefixed with an equals sign (=) indicates the current selection.

■ Message Display



When a device requires attention, the message lamp flashes and the printer stops. In such a case, you must correct the problem.

When a message is displayed to alert you that a device requires attention, you can continue with the print job. With the message lamp on, press any button to switch off the warning display and the lamp.



Note

- When a message is displayed, refer to Chapter 7, “Message Is Displayed”.
(→ P.7-13)

Using the Operation Panel Buttons

The buttons on the operation panel are used for the functions described below.

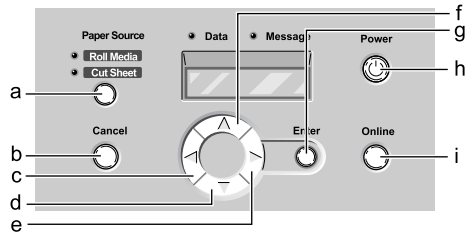

a Paper Source button

Offline:

Press to select Roll Media or Cut Sheet. However, with the Media Take-up Unit installed, this setting is fixed at Roll Media.

b Cancel button

Offline:

Press and hold for over 0.5 seconds to cancel printing, ink drying, or head cleaning and eject the media.

Pause:

Press and hold for over 0.5 seconds to cancel a paused job and eject the media.

c ◀ Button

Offline:

With no media loaded, press and hold for over 1 second to move the carriage to the left.

Menu display:

Press this button to display the previous items on the same level.

d ▼ Button

Offline:

When roll media is loaded, press to feed the media manually. When a cut sheet is loaded, press to eject the media.

Menu display:

Press this button to open the next menu level below.

e ▶ Button

Offline:

Press and hold for over 1 second to move the carriage to the left.

Menu display:

Press this button to display the next item for selection at the same level.

f ▲ Button

Offline:

When roll media is loaded, operates as the manual feed button and reverse feeds media. When a cut sheet is loaded, press to eject the cut sheet.

Menu display:

Press this button to return one level up in the menu tree.

g Enter button

Menu display:

Selects the value or setting, or executes the function, currently displayed on the operation panel.

h Power button

Press this button to switch the printer on and off.

Printer off:

Press to switch the printer on.

Printer on:

Press and hold for 1 second or more to switch the printer off.

i Online button

Press this button to switch printer offline and online, and to open the menu display.

Printer online:

Press to switch the printer to offline.

Printer offline:

Press to open the menu display.

Menu display:

Cancels the menu operation mode and returns the printer online.

However, if an error message is displayed, or if no media is loaded in the printer, the printer does not return online until the problem is corrected.

Job processing:

Puts the printer in the pause mode. The current print job pauses temporarily.

Reading Operation Panel Lamps

The lamps on the operation panel indicate the following states.

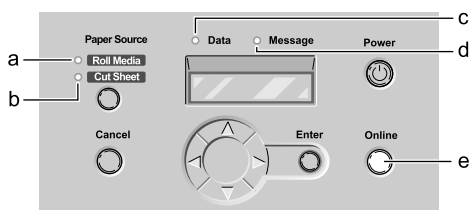

a Roll Media lamp

On: Roll media is selected as the paper source.

b Cut Sheet lamp

On: Cut sheet is selected as the paper source.

c Data lamp

On: The printer is receiving or processing a print job.

Flashing: A paused job is in the printer, or the printer has received a print job that cannot be processed.

Off: There are no jobs in the printer.

d Message lamp

On: A warning is displayed on the operation panel.

Flashing: A error has occurred.

Off: The printer is operating normally, or the printer is switched off.

e Online lamp

On: The printer is online, or the printer is processing a print job.

Flashing: Media is being loaded in the printer.

Off: The printer is offline or pause or the printer is switched off.

Function Menus

This printer is provided with many built-in functions that can be set with the operation panel. The menus allow you to make system and option settings, clean the printhead, print test prints, and display information about the printer settings.

Printer Function Priorities

If the setting is different for the same item in both the operation panel and the printer driver, the printer driver setting has priority over the operation panel setting.

Menu Flow Summaries

The printer operation panel menus are summarized in the flowchart below.

Use the arrow buttons to display the items on the menus.

◀ or ▶ Press to move to the previous or next item on the same level.

▼ Press to move to the next level below.

▲ Press to return to the previous level above.

Enter Press to execute functions.

■ Main Menu

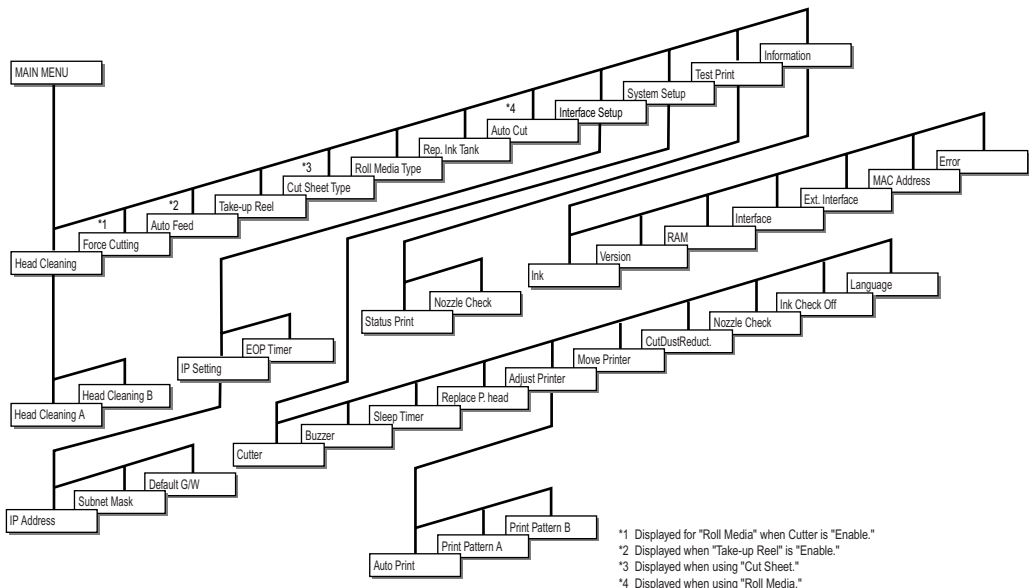

How to Perform Menu Settings

To use the function menus, press the Online button to open the menu display, use the arrow buttons to select settings, then press Enter to save each setting.

Making Settings

The procedure below shows you how to set the sleep timer as an example of how to make settings on the operation panel.

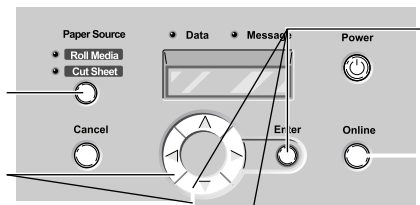

- 1** Press the Power button (h) to switch the printer on.
After a few seconds “Online” is displayed in the operation panel and the Online lamp lights.
- 2** Press the Online button (i) twice to display “MAIN MENU”.
- 3** Press ◀ or ▶ (c, e) to select “System Setup” then press ▼ (d).

The next level of the menu is displayed.

- 4** Press ◀ or ▶ (c, e) to select “Sleep Timer” then press ▼ (d).

The selected value for the item is displayed.

- 5** Press ◀ or ▶ (c, e) to select the value then press Enter (g).



The selected value is prefixed with an equals sign (=).

- 6** Press the Online button (i) . “Online” is displayed.

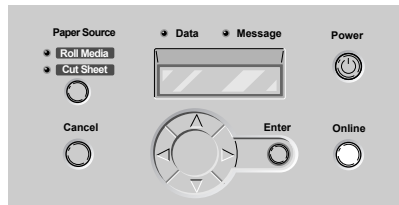

The Online lamp lights and the printer is ready to print.

Menu Settings Summary Tables

The menus provide the functions listed and described in the tables below. Settings marked with an asterisk (*) in the tables are the initial or default values.

Main Menu

Menu Item	Available Settings	Function
Head Cleaning	Head Cleaning A	Cleans the printhead.
	Head Cleaning B	Re-fills the printhead with ink.
Force Cutting * ¹	Yes*, No	Cuts the roll media at the current position under the cutter. However, when the media is within 10 cm (4 in.) of the leading edge, the media is cut after it loads as far as the 10 cm (4 in.) position.
Auto Feed * ²	Yes*, No.	Selects automatic feed for the Media Take-up Unit.
Take-up Reel	Disable*, Enable	Sets the operation for the Media Take-up Unit. When "Enable" is selected, the cutter is automatically switched off.
Cut Sheet Type * ³	(Dye ink printer) Plain Paper*, Coated Paper, Heavy Coated, Glossy Paper, Photo Glossy, Photo Semi-Glos, Glossy Film, Back Print Film, Proofing paper, Special 1~5 (Pigment ink printer) Heavy Coated*, Photo Glossy, Photo Semi-Glos, Syn. Paper, Adh. Syn. Paper, Back Light Film, Flame-Res. Cloth, Special 1~5	Selects the type setting for cut sheet media.
Roll Media Type	(Dye ink printer) Plain Paper*, Coated Paper, Heavy Coated, Glossy Paper, Photo Glossy, Photo Semi-Glos, Glossy Film, Back Print Film, Proofing paper, Special 1~5 (Pigment ink printer) Heavy Coated*, Photo Glossy, Photo Semi-Glos, Syn. Paper, Adh. Syn. Paper, Back Light Film, Flame-Res. Cloth, Special 1~5	Selects the type setting for roll media.
Rep. Ink Tank	No*, Yes	Sets the printer in the replace ink tank mode.

Menu Item	Available Settings	Function
Auto Cut*4	Yes*, Print Cut Line, No	Selects automatic cutting when printing with roll media. If you select "Print Cut Line", a line prints to guide manual cutting.
Interface Setup		
IP Setting		
IP Address Subnet Mask Default G/W		Allows you to set the network information for a TCP/IP network interface. After making each TCP/IP settings, be sure to execute "Regis. Settings" to enable the settings.
EOP Timer	10, 30 sec.; 1, 2, 5, 10, 30, 60 min.*	Sets the job timeout setting for the printer.
System Setup		
Cutter	Enable*, Disable	Switches the roll media cutter on and off.
Buzzer	On*, Off	Switches the buzzer function off and on. When the buzzer is on, it buzzes when an error occurs.
Sleep Timer	off, 5, 10, 20*, 30, 40, 50, 60 min.	Sets the time interval for the printer to remain idle before it enters the sleep mode. If set off, the printer never enters the sleep mode.
Replace P.head	No*, Yes	Sets the printer in the replace printhead mode.
Adjust Printer		
Auto Print	On*, Off	Automatically prints Print Pattern A after replacing the printhead.
Print Pattern A	Adj. Setting A1 ~ A5 Adj. Setting B1 ~ B5 Adj. Setting C1 ~ C5 Adj. Setting D2 ~ D5 Adj. Setting E2 ~ E5	Allows you to adjust the alignment of the printhead to correct color and the direction of printing. Print Patterns A1 to E5 for each step of adjustment.

Menu Item	Available Settings	Function
Print Pattern B	Adj. Setting L~U, V~Z	<p>Allows you to adjust the amount of feed for the media. After selecting the media type, print the pattern for the adjustment and set the value for each type.</p> <p>(Dye ink printer)</p> <p>L: Plain Paper M: Coated Paper N: Heavy Coated Paper P: Glossy Paper Q: Photo Glossy Paper R: Photo Semi-Glossy Paper S: Glossy Film T: Back Print Film U: Proofing paper V~Z: Special 1~5.</p> <p>(Pigment ink printer)</p> <p>L: Heavy Coated Paper M: Photo Glossy Paper N: Photo Semi-Glossy Paper P: Synthetic Paper (Non-Adhesive) Q: Synthetic Paper (Adhesive) S: Back Light Film T: Flame-Resistant Cloth V~Z: Special 1~5</p>
Move Printer	No*, Yes	Sets the printer to the mode that enables you to carry out the procedures required before shipping the printer to another location.

Menu Item	Available Settings	Function
Cut Dust Reduct.		
(Dye ink printer) Plain Paper Coated Paper Heavy Coated Glossy Paper Photo Glossy Photo Semi-Glos Glossy Film Back Print Film Proofing paper Special 1~5 (Pigment ink printer) Heavy Coated Photo Glossy Photo Semi-Glos Syn. Paper Adh. Syn. Paper Back Light Film Flame-Res. Cloth Special 1~5	Off*, On	When printing on roll media, prints a line at the cutting position in order to reduce the amount of dust and cut waste. This setting can be adjusted for each type of media.
Nozzle Check	Off, 1 page, 10 pages*	Sets the printer to check a print nozzle blockage. If a blockage occurs, automatically an auxiliary function substitutes for the blocked nozzle and "Nozzle Check" appears on the display. If set for one page, then the nozzles are checked before every page, and if set for 10, then the nozzles are checked after every 10 pages. The operation time for the nozzle check will require about 30 seconds to 3.5 minutes for the dye pigment printer, or about 1 to 5 minutes for the pigment ink printer.
Ink Check Off	Bk Ink Tank PC Ink Tank C Ink Tank PM Ink Tank M Ink Tank Y Ink Tank	Switches off the ink level detection function.
Language	English*, カタカナ, Français, Deutsch, Italiano, Español	Allows you to select the display language.

Menu Item	Available Settings	Function
Test Print		
Status Print	—	Prints a complete list of all printer settings.
Nozzle Check	—	Prints the nozzle check pattern.
Information		
Ink	—	Displays the amount of ink supply remaining.
Version	—	Displays the version numbers for the printer unit and the firmware.
RAM	—	Displays the memory capacity of the printer.
Interface	—	Displays the names of the interfaces that can be used.
Ext. Interface	—	Displays the name of the interface that can be used at the expansion slot.
MAC Address	—	Displays the MAC address assigned to the computer.
Error	—	Displays the most recent error message.

- *1. Displayed only when “Roll Media” selected as the Media Source and “Cutter” is enabled.
- *2. Displayed only when “Enable” is selected for “Take-up Reel”.
- *3. Displayed only when “Cut Sheet” is selected as the Media Source.
- *4. Displayed only when “Roll Media” is selected as the Media Source.

6

Maintenance

This chapter describes how to replace consumables and maintain the printer.

Replacing Ink Tanks

A message in the printer driver screen or in the printer operation panel display warns you when the ink tank level in a tank so low that it is time to replace the ink tank. Of the six ink tanks, Yellow (Y), Magenta (M), Photo Magenta (PM), Cyan (C), Photo Cyan (PC), and Black (Bk), only the one that runs dry need be replaced.

● Dye Ink Tank

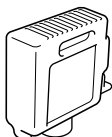

- Yellow Ink Tank BCI-1411Y
- Magenta Ink Tank BCI-1411M
- Photo Magenta Ink Tank BCI-1411PM
- Cyan Ink Tank BCI-1411C
- Photo Cyan Ink Tank BCI-1411PC
- Black Ink Tank BCI-1411Bk

● Pigment Ink Tank

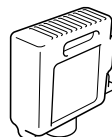

- Yellow Ink Tank BCI-1421Y
- Magenta Ink Tank BCI-1421M
- Photo Magenta Ink Tank BCI-1421PM
- Cyan Ink Tank BCI-1421C
- Photo Cyan Ink Tank BCI-1421PC
- Black Ink Tank BCI-1421Bk

When to Replace an Ink Tank

When either of the two messages below appears, you should have extra ink tanks on hand ready for replacement.



Important

- If you attempt to replace an ink tank with a print job temporarily paused, distortion of the image or blurred colors may occur.

■ When the “X Ink Check” Message is Displayed

When the ink supply becomes low, the ink check message is displayed but printing continues. When this message is displayed, this means that the ink tank will run out of ink very soon. The first letter(s) of the message (“X”) tells you which tank is running low: Y (Yellow), M (Magenta), PM (Photo Magenta), C (Cyan), PC (Photo Cyan), Bk (Black). For example, “Y Ink Check”. After this message is displayed, have the correct color ink tank on hand for replacement.

 **Note**

- When the ink level in a tank is very low, you may not be able to perform Head Cleaning B, or other head cleaning tasks that consume ink. In such a case, perform printhead cleaning (“Head Cleaning”) after replacing the ink tank.

■ When the “Replace X Tank” Message Is Displayed

When an ink tank runs out of ink, the replace tank message is displayed and printing halts. You must replace the ink tank after this message appears. The message contains the letter (“X”) of the tank to be replaced: Y (Yellow), M (Magenta), PM (Photo Magenta), C (Cyan), PC (Photo Cyan), Bk (Black). Always replace an ink tank with a new one of the same color.

 **Note**

- When the ink runs out in two or more ink tanks, the message for each of them is displayed consecutively. After the first ink tank is replaced, the message for the next color is displayed. Be sure to replace the color ink tank for every message displayed.

Handling Ink Tank Precautions

Follow the precautions below when handling ink tanks.

 **Caution**

- Store the ink tanks out of the reach of small children. If a child accidentally ingests ink from an ink tank, contact a physician immediately.

 **Important**

- When replacing the ink tank, confirm whether it is for dye ink or pigment ink before you install it. Installing the wrong ink tanks for the printhead will cause poor quality printing.
- Do not break the seal of the protective packing on an ink tank until you are ready to install it in the printer. After breaking the seal, install the ink tank immediately. Not installing an ink tank immediately after breaking its seal could cause poor printing.
- When installing a pigment ink tank, slowly rotate it from side to side seven or eight times before you break its seal. Not rotating the tank could cause the ink to precipitate, causing poor print quality.
- After breaking the seal on an ink tank, avoid dropping or shaking it. To avoid spilling and damage from stains, never drop or shake an ink tank.

- There may be some ink on or around the ink port of an ink removed from the printer, so always handle a removed ink tank carefully to avoid staining your clothing or the work area.
- An ink tank should be used up within six months after its seal is broken. Not using the ink tank within this time period could cause poor printing.
- Never leave an ink tank removed from the printer for longer than one month. This could lead to ink clogging in the tank and poor printing.

Replacing an Ink Tank

Follow the procedure below to replace any ink tank.

- 1 Press the Online button twice to display “MAIN MENU”.

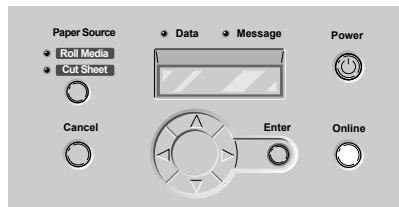

- 2 Press ◀ or ▶ to display “Rep. Ink Tank” then press ▼.

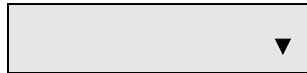

- 3 Press ◀ or ▶ to select “Yes” then press Enter.



The right cover unlocks and opens automatically. If the right cover does not open completely, open it manually.



Important

- You must follow the procedure in Steps 1 to 3 above to open the right cover. To avoid damaging the right cover, never attempt to force it open.

- 4** Press the ink tank lever of the color to replace, then open the ink tank cover.

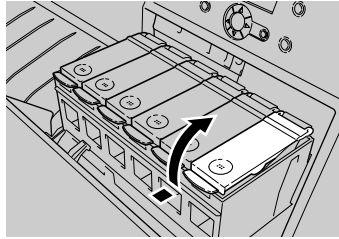

- 5** Hold the empty ink tank by the grips on its side, then remove it.

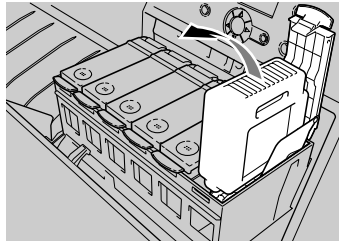

Place the removed ink tank in a vinyl or plastic bag and seal it.



Important

- If there is ink remaining in the removed ink tank, be sure to cover the ink port (a) to prevent the ink from spilling and staining.

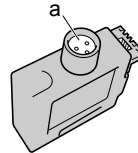

- Discard used ink tanks in compliance with local regulations regarding the disposal of such items

- 6** Remove the new ink tank from its protective cover.

For a pigment ink tank, slowly rotate it from side to side seven or eight times before you break its seal.

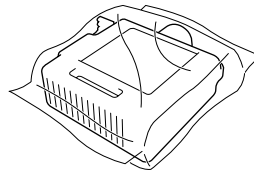



Important

- Always hold an ink tank by the grips (a) on the left and right side of the ink tank.

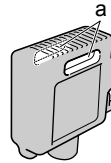

- To prevent poor print quality, spilling ink and staining, never touch the ink ports (b) or the terminal (c) of an ink tank.

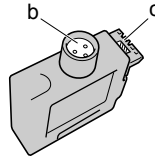

- 7** With the ink ports pointing down and the label facing in the direction shown in the illustration below, insert the ink tank into the ink tank holder.

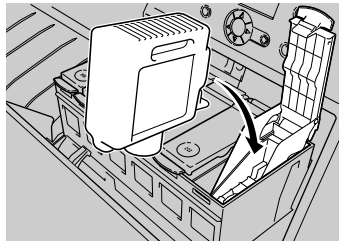

Important

- Always make sure that the ink tank is set in the correct direction and that the color of the tank matches the slot. If the wrong color is inserted in a slot, the ink will mix incorrectly in the tubes and printhead, causing the printer to print the wrong colors.

- 8** Close the ink tank cover until you hear it catch.

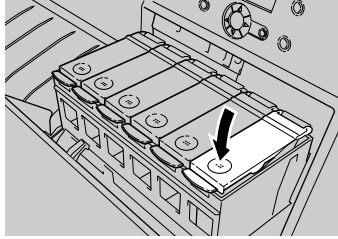

- 9** Repeat Step 4 to Step 8 to install all the other color ink tanks.

- 10** After all the ink tanks have been installed, close the right cover.
Press in on the right cover until you hear it click and lock.

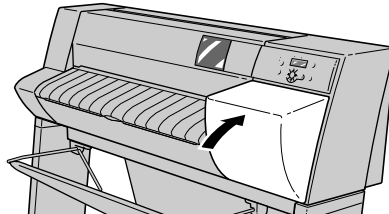

The Online lamp lights and the printer is ready to print.



Note

- If any of the ink tanks are not installed, you will see the message “No X Ink Tank” displayed. Repeat the procedure from Step 1 and make sure that all of the ink tanks are installed.

Caution About Using Refilled Ink Tanks for This Printer

The ink tanks specified for use with this printer are provided with an ink level detection function to prevent the tanks from running out of ink during printing and to prevent damage to the printhead.

When using refilled ink tanks, the printer cannot detect the ink level and stop printing due to ink shortage. If you use such ink tanks, then the ink level detection function must be switched off.

Printing with the ink level detection function switched off could damage the printer, especially the printhead, or could cause the printer to operate abnormally in other ways. Canon is not responsible for damages or injuries caused by such actions.



Caution

- Once the ink level detection feature is switched off, the ink level detection information cannot be recovered. If you want to display the ink level detection information, you must switch the ink level detection function on and then install new ink tanks specified for use with this printer.
- Repeatedly removing the same ink tanks from the printer could cause ink to leak from the tank and damage the printer.

Switching Off Ink Level Detection

- 1** Press the Online button twice to display “MAIN MENU”.
- 2** Press ◀ or ▶ to display “System Setup”, then press ▼.
- 3** Press ◀ or ▶ to display "Ink Check Off", then press ▼.
- 4** Press ◀ or ▶ to display the name of the ink tank (“Bk Ink Tank”, etc.), then press the Enter button.
- 5** When “Execute?” is displayed, press ◀ or ▶ to select “Yes”, then press the Enter button.

The ink level detection feature is switched off for the ink tank you selected.



Note

- Press the Online button to cancel these procedures.

Executing Print Job

After switching ink level detection function off, the “Ink level ?” message will be displayed on the printer operation panel for every print job and the printer will go offline. To continue the print job, on the printer operation panel press the Online button.



- 3** Dampen a clean cloth, wring it out completely, then use it to clean the printer exterior surfaces, tray, ventilation vent (a), and power cord plug. After cleaning, make sure that everything is free of dirt and paper dust, then use a clean, dry cloth to wipe dry the cleaned surfaces.

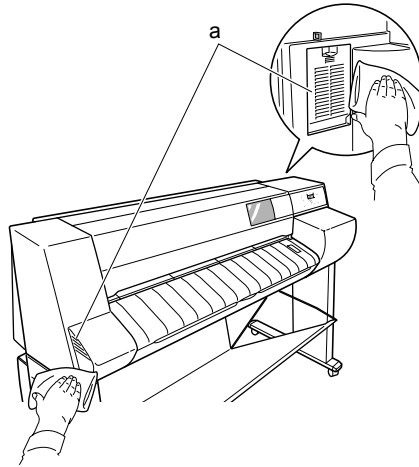

- 4** Plug the power cord into the power source.

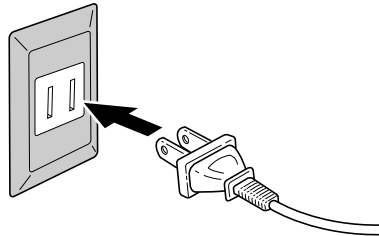

Cleaning Inside the Upper Cover

To achieve the best performance with the printer, clean inside the upper cover if the print surface or reverse side of the media is dirty, or at least once a month.

You should check the platen and clean the platen and inside the printer after printing on small size media.

- 1 Press and hold the Power button for 1 second or more until the Online lamp goes off, release the button, then switch the printer off.

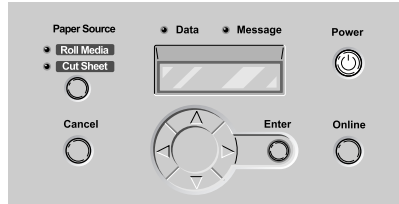

- 2 Disconnect the power cord from the power source.

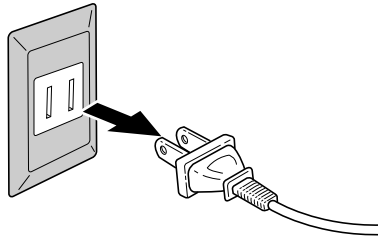

- 3 Open the upper cover.

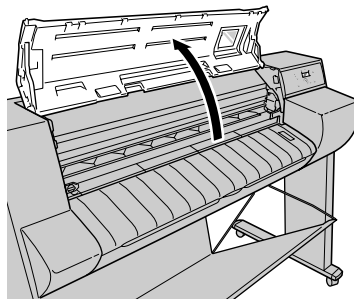

Important

- To avoid soiling your hands or damaging the printer, never touch any part inside the printer unless instructed to do so.

- 4** Dampen a clean cloth, wring it out completely, then use it to wipe clean upper cover handle (a), entire platen area (b), tray (c), upper cover roller (d), guide rail (e) and paper release lever (f).

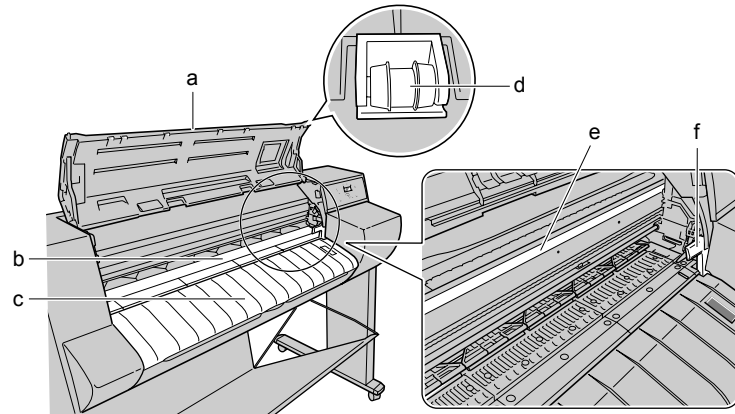

Important

- To avoid creating a static charge that could attract paper dust and dirt that can cause poor printing, never use a dry cloth to wipe inside the upper cover.
- When you clean the guide rail (e), wipe clean only the upper part of the front surface and avoid touching the belt below. Touching the belt could damage the printer.

- 5** Close the upper cover.

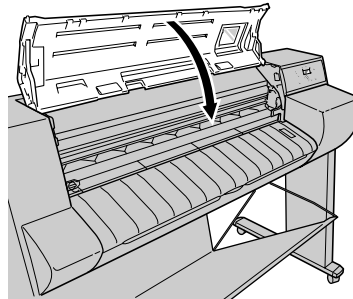

- 6 Plug the power cord into the power source.

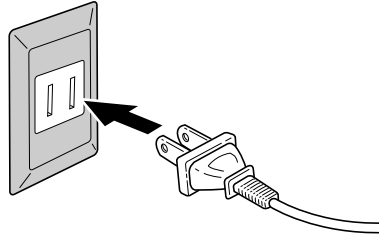

Cleaning the Paper Restraint

To achieve the best performance with this printer, use plain paper to clean the reverse side of the paper restraint when the print side or reverse side of the media is dirty, or at least once a month.

Before starting this procedure, prepare some plain paper (or any media other than film).



Important

- Use a sheet of plain paper for the cleaning, a cut sheet or a cut from a roll of plain paper that does not shred easily. The reverse side of film has a tendency to hang up and shred and could cause poor printing if used in this cleaning procedure.

- 1** Press and hold the Power button for 1 second or more until the Online lamp goes off, release the button, then switch the printer off.

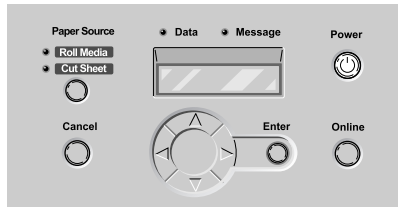

- 2** Disconnect the power cord from the power source.

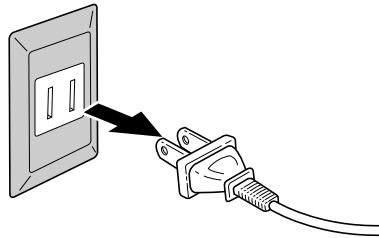

- 3** Fold a sheet of plain paper (a) 2 or 3 times, then insert it from the back of the printer below the lower surface of the paper restraint (b), then use the paper to clean.

Be sure to clean the entire surface of the paper restraint.

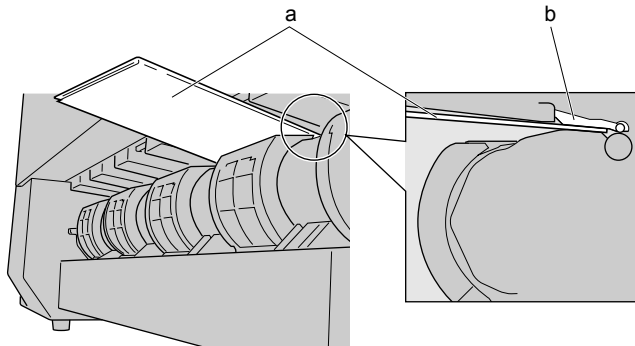

- 4** Plug the power cord into the power source.

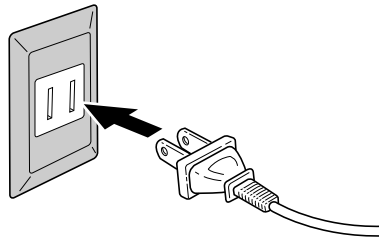

Cleaning the Carriage Rail

To achieve the best performance with this printer, clean the carriage rail at least once a year or when the printhead is replaced. Use the rail cleaner provided with the printer to clean the carriage rail.

- Rail cleaner

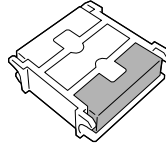

Note

- The white sponge on the rail cleaner takes up dirt as it cleans. If the rail cleaner fails to clean, or if the cleaner fails to clean smoothly, replace the sponge.
- The black sponge of the rail cleaner is used to wipe and dry the rail.

- 1** Press and hold the Power button for 1 second or more until the Online lamp goes off, release the button, then switch the printer off.

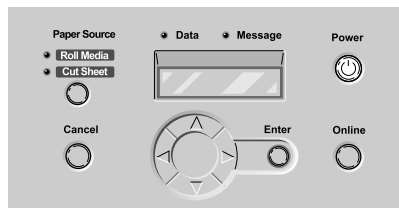

- 2** Disconnect the power cord from the power source.

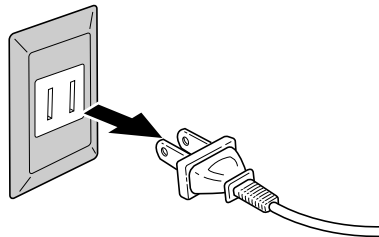

Important

Replacing the Printhead

Replace the printhead after two unsuccessful Printhead B cleanings do not restore high quality printing, or after calling a Help Desk or service center in response to a printer service call error and the service technician directs you to replace the printhead. Ink may spill onto your hands when you are changing the printhead, so we recommend that you use the gloves provided in the printhead package to handle the printhead during this procedure.



Note

- Contact a Canon service center for details about how to obtain a replacement printhead.
- When the ink supply runs low in an ink tank, procure a new ink tank for replacement as soon as possible.

Handling Printhead Precautions

Always follow these precautions when handling a printhead.



Caution

- Store the ink tanks out of the reach of small children. If a child accidentally ingests ink from an ink tank, contact a physician immediately.
- To avoid personal injury from a minor burn, never touch the printhead immediately after printing has stopped. The printhead becomes extremely hot during printing.



Important

- When replacing the printhead, confirm whether it is for dye ink or pigment ink before you install it. Replacing the wrong printhead for the ink tanks cause poor quality printing.
- To avoid spilling and damage from stains, never drop or shake the printhead.
- There may be some ink on or around the ink port of a printhead removed from the printer, so always handle a removed printhead carefully to avoid staining your clothing or the work area.
- Do not break the seal of the protective packing on a printhead until you are ready to install it in the printer. After breaking the seal, install the printhead immediately. Not installing a printhead immediately after breaking its seal could cause poor printing.
- To avoid poor printing as a result of damaged nozzles, never place the printhead on a surface with the nozzles pointing down.
- To avoid damaging the printer, never attempt to disassemble or modify the printhead.
- To avoid poor quality printing, never touch the nozzles or electrical contacts on the printhead.

How to Replace the Printhead

Before replacing the printhead, you must first replace the two filters provided with the printhead package. To replace the printhead, you must select “Replace P.head” from the “System Setup” menu and then follow the instructions on the printer operation panel.

- Remove printed and other media from the tray.
- Clean the carriage rail and the paper restraint. (→ P.6-14, P.6-16)
- Replace the filters (→ Instructions provided with the filters)
- Execute “Replace P.head” on the printer operation panel.
- After ink has drained from the printhead, remove it.
- Install the new printhead.



Important

- You must follow exactly the procedure below when you replace the printhead. If you fail to follow procedure, the printhead may leak and stain the work area.
- When you replace the printhead, you must also replace the filter. If the filter is not replaced, this could interfere with the performance of the printer.

- 1 Press the Power button to switch the printer on.

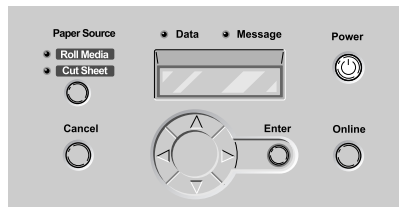

After a few seconds “Online” is displayed in the operation panel and the Online lamp lights.

- 2 Press the Online button twice to display “MAIN MENU”.

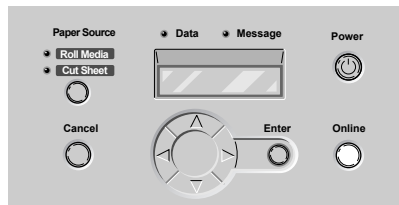

- 3** Press ◀ or ▶ to select “System Setup” then press ▼.



“System Setup” menu opens.

- 4** Press ◀ or ▶ to select “Replace P.head” then press ▼.



- 5** Press ◀ or ▶ to select “Yes” then press Enter.



“Please Wait” is displayed, and the preparation for printhead replacement begins. Preparation requires about 3 minutes.

When preparation is finished, “Open UpperCover” is displayed.

- 6** Open the upper cover.

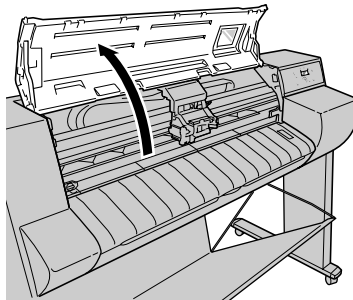

Important

- To avoid soiling your hands or damaging the printer, never touch any part inside the printer unless instructed to do so.
- Check the carriage cover, printhead lock cover, and the printhead lock lever. If one or more of these items is dirty, clean them with a damp cloth before you replace the printhead.

- 7** Raise the carriage cover and open it completely.

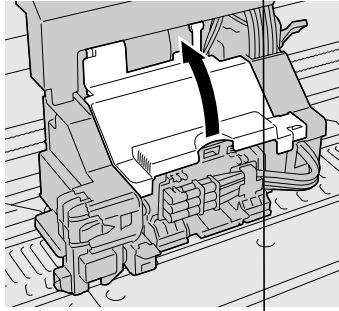

- 8** Pull the printhead lock lever completely forward to open it.

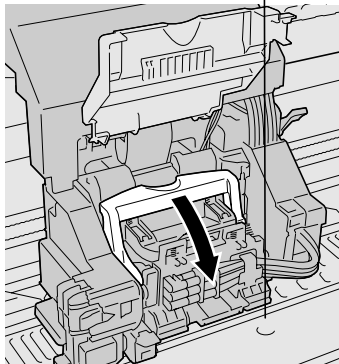

- 9** Raise the printhead lock cover completely to open it.

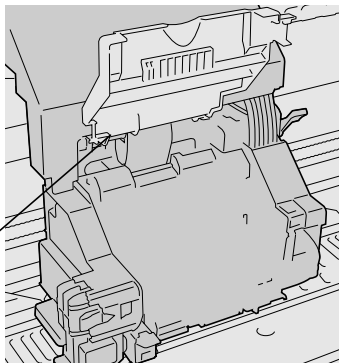

10 Remove the old printhead.

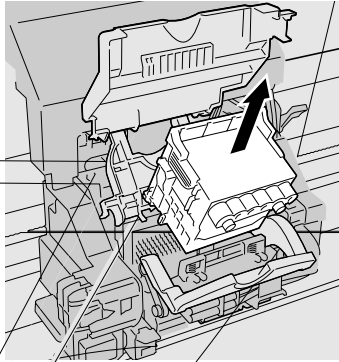

Caution

- If you are removing the printhead immediately after printing, allow the printhead to cool for a few minutes (the metal parts of the printhead become extremely hot during printing). To avoid minor burns, do not touch these metal parts when you remove the printhead.

Important

- To avoid damaging the printer, never touch the electrical contacts on the carriage.
- Discard a used printhead in compliance with local regulations regarding the disposal of such items.

11 Hold the new printhead by the grips (a) on both sides of the printhead and remove it from its case. Remove the orange protective cap 1 (b), then while pressing in on the grips (d) on both sides as shown in the illustration, pull down to remove protective cap 2 (c).

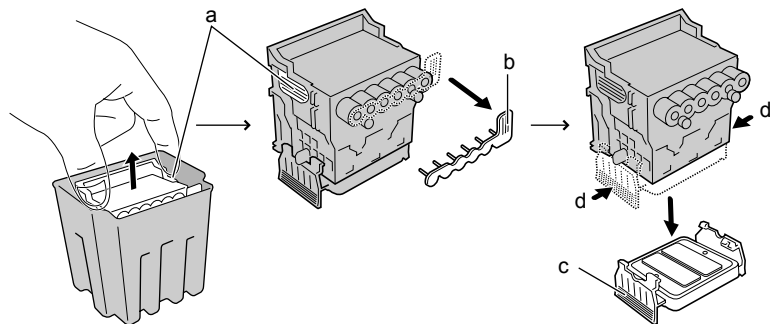



Important

- The nozzles under protective cap 2 (c) are covered with ink. Handle the printhead carefully to avoid touching these nozzles or dropping the printhead and causing ink stains.
- When handling the printhead, always hold it by the grips (a) on the left and right sides of the printhead.
- To prevent damaging the printhead or poor printing results, never touch the exposed nozzles (e) or electrical contacts (f) on the printhead.

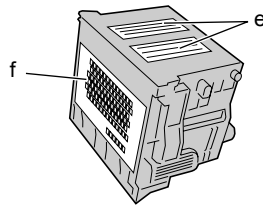

- Never try to re-attach the protective caps or packing material removed from the printhead. Discard these items immediately in compliance with local regulations regarding the disposal of such items.

12 With the nozzles pointing down and the electrical contacts facing the printer, insert the new printhead into the carriage.

Handle the printhead carefully so its nozzles do not touch the carriage, then press down to ensure that it is installed completely.

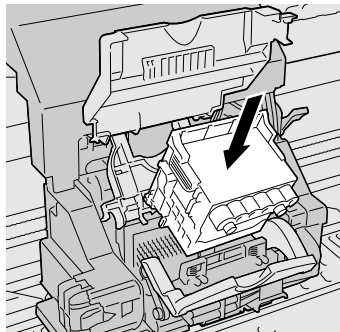

- 13** Lower the printhead lock cover toward you to lock the printhead in place.

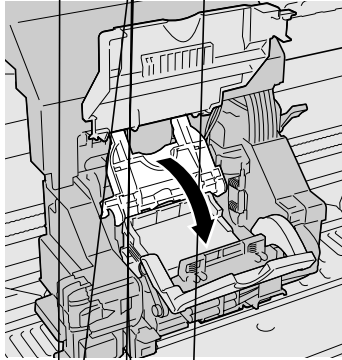

- 14** Raise the printhead lock lever and push it in until you hear it catch.

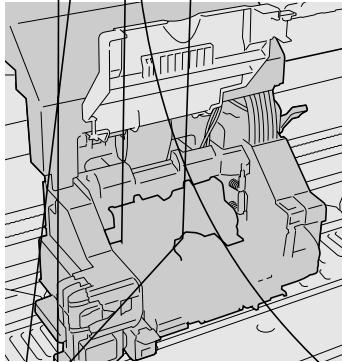

- 15** Pull the carriage cover down and forward until you hear it catch.

16 Close the upper cover.

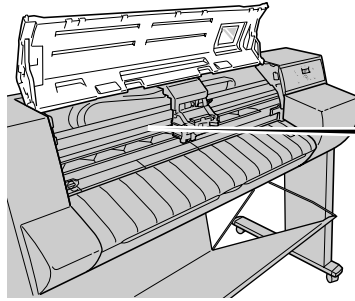

After the upper cover is closed, “Please Wait..” is displayed and processing begins. Processing requires about 3.5 minutes for the dye ink printer and about 17 minutes for the pigment ink printer. When the processing is finished, Print Pattern A prints automatically.

Now you should adjust the printhead. (→ Chapter 7, “Aligning the Printhead”, P.7-35)



Important

- Print Pattern A cannot execute if either “Auto Print” or “Off” is displayed on the operation panel. After replacing the printhead, execute “Print Pattern A” then align the printhead. (→ P.7-35)



Troubleshooting

This chapter describes how to solve problems with the printer.

Having a Problem?

If the printer is not operating as you think it should or if you experience any other problems, read in order through the list below, select the heading that best describes your problem, then go to the referenced page.

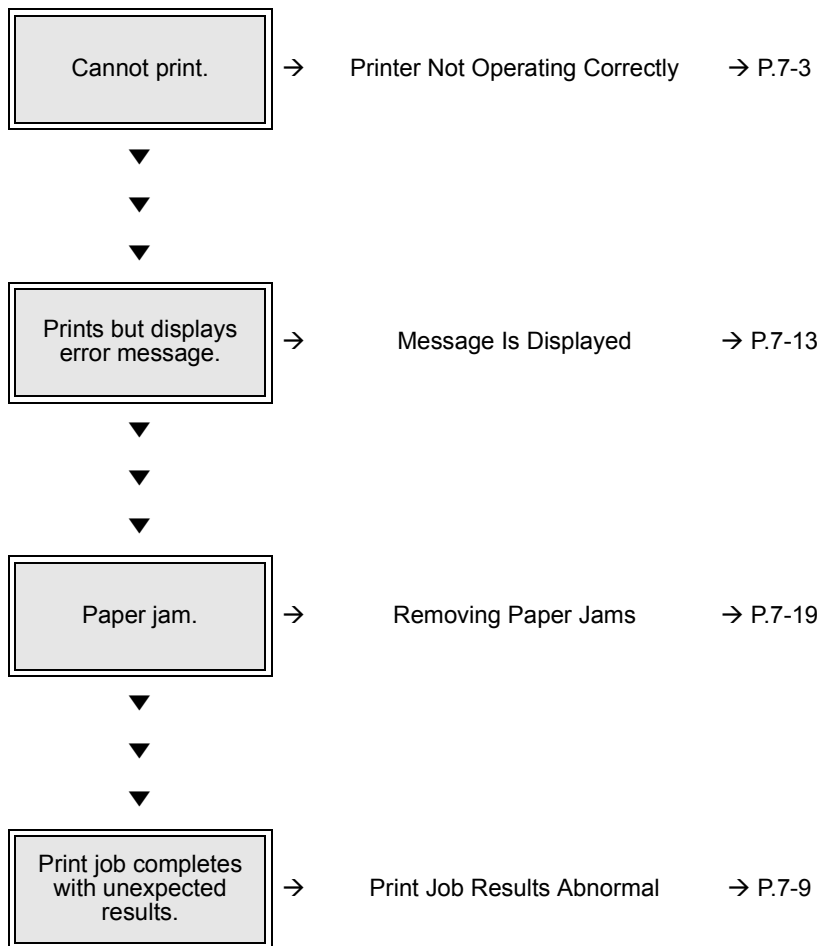

Printer Not Operating Correctly

Check the following items when the printer does not operate and will not print.

Cannot Print

Printer Not Switched On

Problem 1: Power button not switched on.

Solution: Press the Power button again to confirm that the Online lamp, Message lamp, and operation panel light. (→ P.1-9)

Problem 2: Power cord not supplying power to the printer.

Solution: Confirm that the power cord connections at the printer and the power supply are tight. (→ Setup Guide)

Problem 3: Power supply not providing power.

Solution: Connect another device to the power supply to confirm that the outlet is providing power. If not supplying power, check the breaker switches for the power line.

Problem 4: Power cord broken.

Solution: Call for service and request a new power cord.

Printer Is On But Not Online

Problem 1: Printhead is not installed.

Solution: Install the printhead. (→ Setup Guide)

Problem 2: Ink tank(s) not installed.

Solution: Confirm that all ink tanks are installed. (→ Setup Guide)

Problem 3: No print media loaded.

Solution: Load roll media or a cut sheet. (→ P.2-8, P.2-19)

Problem 4: A cover is open.

Solution: Close the cover named in the message displayed on the operation panel.

Problem 5: Printer is still warming up.

Solution: Immediately after the printer is switched on, it cannot print because it needs a several seconds to warm up. After switching on the printer, you must wait for the Online lamp to light and remain on.

Cannot Install Windows Printer Driver

Problem 1: Incorrect CD-ROM mounted.

Solution: Mount the User Software CD-ROM provided with the printer.

Problem 2: User Software CD-ROM is damaged.

Solution: Call for service and request a new installer CD-ROM. You can also download the driver from the Canon Home Page (<http://www.canon.com/>).

Problem 3: Windows operating system is unstable.

Solution: If Windows displays a system error message such as “General Protection Fault” or “Illegal Operation”, the computer system has become unstable. Confirm the problem with the system and try to install again.

Problem 4: Installation does not complete successfully.

Solution: Delete the Printer icon then try to install again. (→ Setup Guide)

Cannot Install Macintosh Driver

Problem 1: Incorrect CD-ROM mounted.

Solution: Mount the User Software CD-ROM provided with the printer.

Problem 2: Provided User Software CD-ROM is damaged.

Solution: Call for service and request a new installer CD-ROM. You can also download the driver from the Canon Home Page (<http://www.canon.com/>).

System Does Not Recognize the Printer

Problem 1: Interface cable is disconnected.

Solution: If the printer is connected via the USB or IEEE1394 port, check the cable connections at the printer and the computer. (→ Setup Guide)

Problem 2: The driver is not installed correctly for the printer connected via a Windows USB port or IEEE1394 port.

Solution: Follow the procedure below to install the driver.

- ▼ Right click the My Computer icon then select Properties.
- ▼ On the Hardware sheet, click Device Manager. Next, in the Device Manager window click the Unknown devices icon then click the Properties button.
- ▼ Click the General tab then click the Reinstall Driver button. When the Update Device Driver Wizard opens, follow the instructions on the screen to complete the installation.
- ▼ When the Wizard prompts you to select how to search for the driver source files, select only “CD-ROM drive”. Set the User Software CD-ROM in the CD-ROM drive then follow the on-screen instructions to install the interface driver.
- ▼ Next, when the Add New Hardware Wizard opens, follow the instructions on the screen.
- ▼ Select only “Specify a location” then click the Browse button.
- ▼ If you are using Windows Me/Windows 98, open the CD-ROM Drive, open the appropriate language folder, open the Drivers folder, open the WinMe_9X folder, open the Driver folder, then click the OK button. For Windows XP/Windows 2000, open the CD-ROM, open the appropriate language folder, open the Drivers folder, open the WinXP_2k folder, open the Driver folder, then click the OK button.
- ▼ Confirm that the correct folder has been selected for “Specify a location”, then install the driver.

Problem 3: The printer is connected to the LAN, but the LAN communication method is not detected automatically.

Solution: On the back of the printer, set the DIP switches to the correct settings for the LAN in use. (→ Setup Guide)

Problem 4: The destination via the Macintosh network is not set.

Solution: If the printer is connected to a Macintosh network, open AppleTalk on the Control Panel then make the settings for “Connect To” and “Zone”.

Problem 5: The network information for the printer has not been set.

Solution: If the printer is connected to a Windows network, use the printer operation panel to make the network settings. (→ Setup Guide)

Solution: If the printer is connected to a Macintosh network, use the Remote UI to select “Phase 2” for the AppleTalk protocol.

Printing Does Not Start

No error message is displayed.

Problem 1: Printer is not selected as the destination for the print job.

Solution: If you are using Windows or Mac OS X, make sure that the correct name of the printer is selected in the name box of the Print dialog box, then try again.

Solution: If you are using Mac OS 8/9, make sure that the correct name of the printer is selected with the Chooser.

Problem 2: Print queue has halted.

Solution: With Windows, open the Printer window and click the printer icon. Open the File menu and click Pause Printing to release the print job from paused printing.

Solution: With Mac OS 8/9, open GARO Printmonitor, then select Resume Printing from the File menu to release the print job from paused printing.

Solution: With Mac OS X, open Print Center, select Resume Printing from the job menu.

Problem 3: With Mac OS 8/9, the printer is shared via USB.

Solution: Connect the printer directly to the USB board or IEEE1394 board. If you want to share the printer, then connect it from a Windows computer.

Error message is displayed.

Problem 1: Paper jam has occurred.

Solution: Remove the jammed paper. (→ P.7-19)

Problem 2: Printer is offline.

Solution: After correcting the problem in response to the error message, press the Online button to set the printer online.

Solution: If the operation panel display reads “Offline”, press the Online button to set the printer online.

Problem 3: Error message appears during print job.

Solution: When an error message appears in the printer operation panel or the Windows display, read the message in the GARO Status Monitor, or in the GARO Printermonitor for Macintosh. Then correct the problem.
(→ P.7-13)

Problem 4: No print media loaded.

Solution: Replenish the print media in the designated feed source.

Problem 5: The “Media Size” and “Media Type” selections are not selected.

Solution: Use the printer operation panel to select the correct setting for the media type. (→ P.2-8, P.2-19)

Solution: If the Media Type selection is incorrect, cancel the print job, open the printer driver and select the correct setting for the print media loaded.
(→ P.3-4, P.4-7)

Problem 6: Ink has run out, or the printhead nozzles are clogged.

Solution: Print a nozzle check pattern and check the ink supply and the condition of the printhead.

If the ink supply has run out in one or more ink tanks, replace them.

(→ P.6-2)

If the nozzles are clogged, clean the printhead. (→ P.7-33)

Ink initialization operation starts unexpectedly.

Problem 1: When the printer was switched off previously, this force cancelled a cleaning operation.

Solution: Wait for the ink initialization operation to finish. Ink initialization may require up to 30 minutes to finish.

Printing Halts During Print Job

Error message is displayed.

Problem 1: An error message is displayed during printing.

Solution: Read the message displayed in the GARO Status Monitor or GARO Printmonitor, and correct the problem indicated by the error message.
(→ P.7-13)

Problem 2: The specified Media Source is not correct for the media loaded in the paper supply source.

Solution: Confirm the current selection for the Media Size. If the setting is not correct, stop the print job, select the correct setting, then start the print job again. (→ P.2-8, P.2-19)

Problem 3: Roll media ran out during the print job and the tape on the trailing edge of the media sheet is preventing the rest of the sheet from feeding.

Solution: Follow the procedure for removing a media jam. Remove the used roll and replace it with a new one. (→ P.2-8, P.7-19)
Send the data again in order to restart the print job.

Solution: If you are using the Media Take-up Unit, remove previously printed media from the Media Take-up Unit. (→ P.2-39)

Blank paper is ejected from the printer.

Problem 1: A blank page is ejected from the previous print job.

Solution: The print job starts after the blank page is ejected.

Problem 2: The leading edge of the roll media is cut to an even length.

Solution: When the roll media was loaded, the ejection of a plain cut sheet was a normal part of the procedure in order to align the roll media correctly.
When the preparation is finished, the printer is ready to print.

Problem 3: Printhead nozzles are clogged.

Solution: Print a nozzle check pattern, check the condition of the printhead nozzles, If you determine that the printhead nozzles are clogged, clean the printhead. (→ P.7-33)

Problem 4: An ink tank has run out of ink.

Solution: Check the ink tanks and replace any empty ink tanks. (→ P.6-2)

Problem 5: Printer is damaged.

Solution: Call for service.

Print Job Results Abnormal

If the results you see in the print job are not what you expect, check the items described below.

Poor Print Quality

Printing is faint.

Problem 1: Printing on the wrong side of the sheet.

Solution: Determine which side is the correct print side. Some Media will not print correctly if printed on the back.

Problem 2: Ink supply in one or more tanks is running low.

Solution: Check the level of the ink in the tanks and replace a tank if it is nearly empty. (→ P.6-2)

Problem 3: Printhead nozzles are clogged.

Solution: Print a nozzle check pattern, check the condition of the printhead nozzles, If you determine that the printhead nozzles are clogged, clean the printhead. (→ P.7-31, P.7-33)

Problem 4: Ink filling is not completed.

Solution: If you can see bubbles in the ink hoses, perform Head Cleaning B. (→ P.7-33)

Problem 5: The ink port needle is stuck and the ink has clogged.

Solution: If the printer has not been used for more than 24 hours, execute Print Head Cleaning B. (→ P.7-33)

Ink Smearred

Problem 1: Printing with high density ink on plain paper.

Solution: Lower the Intensity setting (print density) in the printer driver. (→ Printer Driver Help)

Problem 2: The selected Media Type does not match the media loaded in the paper supply source.

Solution: Confirm the current selection for the Media Type. If the setting is not correct, stop the print job, select the correct setting, then start the print job again. (→ P.2-8, P.2-19)

Problem 3: The printhead height adjustment lever is at the down position.

Solution: Set the printhead height adjustment lever to the center position for normal printing. (→ P.2-27)

Problem 4: You are printing on thick paper or paper that buckles easily.

Solution: Make sure that the print height adjustment lever is set to the up position. (→ P.2-27)

Edges Smearred with Ink

Problem 1: The selected Media Type is not correct for the media loaded in the paper supply source.

Solution: Confirm the current selection for the Media Type. If the setting is not correct, stop the print job, select the correct setting, then start the print job again. (→ P.2-8, P.2-19)

Problem 2: Print media is curled or creased.

Solution: Remove the creasing or curling then start the print job again.

Problem 3: The cutting dust reduction function is switched on.

Solution: If the cutting dust reduction function is not needed, use the operation panel to switch off this feature for the print media in use.

Black Streaks Visible

Problem 1: Printhead is out of alignment.

Solution: Use the operation panel to adjust the amount of feed for the print media in use. (→ P.7-38)

Problem 2: Printing is not proceeding smoothly due to an interruption in the flow of data from the computer.

Solution: Close other applications that are open and cancel other jobs that are executing.

Fine horizontal lines appear in images printed on backlight film or synthetic paper.

Problem 1: Standard is selected for Print Quality.

Solution: In the printer driver, select High or Highest for Print Quality.

Print Results Do Not Match Print Job Content

Broken lines are visible.

Problem 1: Printhead is out of alignment.

Solution: Use the printer operation panel to align the printhead. (→ P.7-35)

Random, Bizarre characters are printing.

Problem 1: Data from the print job data stream has been lost.

Solution: Switch the printer and computer off, then switch them on again and start the print job again.

Problem 2: Another printer driver was selected for the print job.

Solution: Select the correct printer driver for the printer and try again.
(→ Setup Guide)

Problem 3: Font selected for printing not supported.

Solution: Make sure that the font used in the text of the software application has been installed correctly. For details, see your software application manual.

Colors Wrong

Only one color is printing.

Problem 1: Monochrome printing is selected in the printer driver for the print job.

Solution: On the Main tab of the printer driver, select Color for the Color Mode and try again. (→ Printer Driver Help)

Problem 2: Ink supply has run low in one or more ink tanks.

Solution: Check the level of the ink in the tanks and replace a tank if it is nearly empty. (→ P.6-2)

Wrong colors are printing.

Problem 1: The printer driver is not performing color adjustment.

Solution: Use the printer driver to adjust the colors with the settings on the Color Settings of the Color Mode dialog box. (→ Printer Driver Help)

Problem 2: Colors in the printout do not match the colors on the screen.

Solution: Perform monitor color correction. (→ Monitor Instructions)

Solution: The color management setting in the software application is not set correctly. For details, see your software application manual.

Problem 3: Color ink is running low.

Solution: Check the level of the ink in the tanks and replace a tank if it is nearly empty. (→ P.6-2)

Problem 4: Not enough ink is being supplied to the printhead.

Solution: On the printer operation panel, perform Head Cleaning B. (→ P.7-33)

Problem 5: A color ink tank is inserted in the wrong slot.

Solution: On the printer operation panel, select “Move Printer”. Remove the ink tank from the printer, then insert the correct color ink tank. (→ Setup Guide)

Solution: After doing the above procedure, execute “Nozzle Check”. If each color is not printing correctly, on the printer operation panel execute “Head Cleaning B”. (→ P.7-31, P.7-33)

Image Color Borders Printing Dark

Problem 1: Ink is clogged in a nozzle.

Solution: Open the printer driver, click the Device Settings tab then select SSC Adjustment. If the Level 1 setting is not satisfactory, select Level 2 then try again. However, using this feature could change the hues of the overall image, so watch carefully the affects of the changes on the hues in the printed image.

Other Problems

Ink consumption is exceedingly high.

Problem 1: Printing a color image over a large printing area.

Solution: Printing a photograph or other large image consumes a large amount of ink. This is not abnormal.

Printer suddenly becomes very quiet.

Problem 1: The fan has shut down because the printer is checking the printhead nozzles.

Solution: This is not a malfunction or breakdown. Wait for the nozzle check operation to finish.

Message Is Displayed

GARO nnnnn ("n" = numbers)

Problem 1: Error in the print data.

Solution: If the job does not print correctly, check the settings then restart the print job.

x Ink Check ("x" = Letter code for the ink tank)

Problem 1: Ink in the ink tank of the displayed color is running low.

Solution: Read the message to determine the color ink tank then make sure that you have a new ink tank on hand. Before starting a print job on a very long sheet, or before printing multiple copies of a large print job, you should check the ink tanks before starting the print job.

No x Ink Tank ("x" = Letter code for the ink tank)

Problem 1: The ink tank of the displayed color is not installed.

Solution: Read the message and select the correct color ink tank for replacement. Make sure that the ink tank is installed correctly. (→ P.6-2)

Problem 2: A problem has occurred with the ink tank.

Solution: Install a new ink tank. (→ P.6-2)

Check x Tank ("x" = Letter code for the ink tank)

Problem 1: The ink tank indicated by the message cannot be used with this printer, or an empty tank was installed.

Solution: Make sure that the indicated ink tank is installed correctly. (→ P.6-2)

Replace x Tank ("x" = Letter code for the ink tank)

Problem 1: The ink tank of the color designated by the message has run out of ink.

Solution: Replace the color ink tank with a new one. Before starting a print job on a very long sheet, or before printing multiple copies of a large print job, you should check the ink tanks before starting the print job. (→ P.6-2)

Solution: When printing on the long-format media, replace the displayed ink tank indicated on the screen with a new one. Then start print job again after selecting "Force Cutting" on the operation panel.

Ink level ?

Problem 1: The ink level detection function is set to off.

Solution: The message is displayed when the print job is executed, and the printer is set to offline. Press the Online button to continue the print job.

Solution: To retrieve the ink level display, replace with the ink tanks specified for use with this printer.

Cut Failed

Problem 1: Leading edge of the roll media not detected after cutting.

Solution: The cutter cut off the end of the media. Re-load the roll media. (→ P.2-8)

Load Cut Sheet

Problem 1: The tray is waiting for a cut sheet to be loaded.

Solution: Load the cut sheets in the tray and press the Online button, or cancel the print job. (→ P.2-19)

Eject Cut Sheet

Problem 1: The printer received print data for the roll media while a cut sheet was loaded.

Solution: Remove the cut sheet and load the roll media. (→ P.2-8)

Remove Cut Sheet

Problem 1: The tray is waiting for a cut sheet to be removed.

Solution: Remove the cut sheet from the tray. (→ P.2-19)

Close xxx Cover (“xxx” name of the cover)

Problem 1: The named cover named is open.

Solution: Close the named cover.

Feed Limit

Problem 1: You pressed ▲ on the operation panel to feed more media than allowed.

Solution: Open the tray, then turn the roll holder manually to feed the extra media.

Size Undetected

Problem 1: The media has shifted out of the correct load position, or the media is curled.

Solution: Set the media correctly. (→ P.2-9, P.2-21)

Problem 2: The printer interior is dusty or dirty.

Solution: Open the upper cover and clean inside the printer. (→ P.6-11)

Remove Ink Tank

Problem 1: Right cover was closed without removing the ink tank.

Solution: Remove the ink tank.

Turn Power Off!!

Problem 1: The tape inside the upper cover or the belt stopper have not been removed.

Solution: Switch the printer off, open the upper cover, remove the tape and belt stopper, then press the Power button. (→ Setup Guide)

Problem 2: The printer has malfunctioned.

Solution: Switch the printer off, then press and hold down the Power button for over 3 seconds to switch the printer on again.

Solution: If the message occurs again after switching the printer off and on, note the message in the first line of the operation panel display, then call for service.

W-Ink Full Soon

Problem 1: The waste ink tank is nearly full and requires replacing very soon.

Solution: Printing can continue after this message is displayed. However, you should call for service as soon as possible before a Service Call is issued.

Check Printouts

Problem 1: Cannot adjust nozzle to correct blockage.

Solution: Execute “Head Cleaning B”. (→ P.7-33)

Solution: Press the Online button to continue printing.

No Printhead

Problem 1: The printhead is not installed.

Solution: Install the printhead correctly. (→ P.6-19)

Check Printhead

Problem 1: The printhead is not installed.

Solution: Install the printhead correctly. (→ P.6-19)

Problem 2: The printhead installed cannot be used with this printer.

Solution: Install the printhead for this printer. (→ P.6-19)

Problem 3: Printhead abnormal.

Solution: Open the upper cover. If the carriage is out, replace the printhead. (→ P.6-22). If the carriage is in, close the upper cover, press the Online button, select “Replace P.head”, then replace the printhead. (→ P.6-19)

Memory Overflow

Problem 1: Print job cannot be processed due to the large amount of data.

Solution: Check and lower the resolution and quality settings in the printer driver.

Solution: Use the banner printing feature to divide the job.

No Media

Problem 1: The media in the selected source has run out.

Solution: Load the media then press the Online button. (→ P.2-8, P.2-19)

Media Too Large

Problem 1: The loaded media is larger than any media size allowed for loading in the printer.

Solution: Set the correct size media then try again. (→ P.2-8, P.2-19)

Media Skewed

Problem 1: The loaded media is skewed.

Solution: If roll media is in use, open the upper cover, raise the paper release lever, open the roll media tray, take-up some of the media manually to correct the skew then try again. (→ P.2-8)

Solution: If a cut sheet is in use, open the upper cover, raise the paper release lever, remove the cut sheet, set it again then retry. (→ P.2-19)

Media Too Small

Problem 1: The loaded media is smaller than any media size allowed for loading in the printer.

Solution: Set the correct size media then try again. (→ P.2-8, P.2-19)

Media Jam

Problem 1: Media has jammed in the printer.

Solution: Remove the jammed media then press the Online button. (→ P.7-19)

Incorrect Media

Problem 1: The media type specified by the printer driver does not match the value for the media in the paper feed source.

Solution: Confirm the type of media loaded in the printer, then select the media type with the operation panel. (→ P.2-18, P.2-26)

Solution: Pause the print job, use the printer driver to correct the media type so it matches the loaded media, then re-start the job.

End of Roll

Problem 1: The roll media has run out.

Solution: Load another roll in the roll media tray, then press the Online button.
(→ P.2-8)

Load Roll Media

Problem 1: The printer is waiting for roll media be loaded in the roll media tray.

Solution: Load the specified print media in the roll media tray and press the Online button. (→ P.2-8)

Remove Roll Media

Problem 1: The printer is waiting for removal of the roll media from the tray.

Solution: Remove the printed roll media from the tray then press the Online button.

Removing Paper Jams

When a paper jam occurs, the “Media Jam” or “Turn Power Off !!” message is displayed on the operation panel and the print job stops. Follow the procedure below to check each location for paper jams and remove the jammed sheets.

Removing a Roll Media Jam

Follow the procedure below to remove a roll media jam.

■ Jam During Roll Media Preparation

- 1 Open the tray, pull the tray open lever, then pull out the roll media tray.

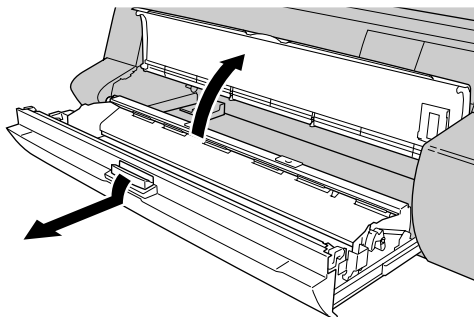

- 2 Rotate the roll holder in the direction shown in the illustration so you can see the leading edge of the roll, then cut the media at the buckle.

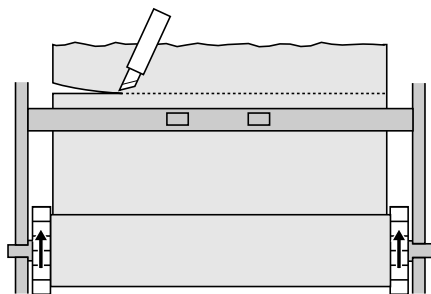

Caution

When cutting the media, work carefully to avoid cutting your hand on the cutting blade or leading edge of the media.



Note

...ining the center of the roll media, turn the roll holder to
...buckle in the media, pull the roll release lever toward you,
...e paper guide.

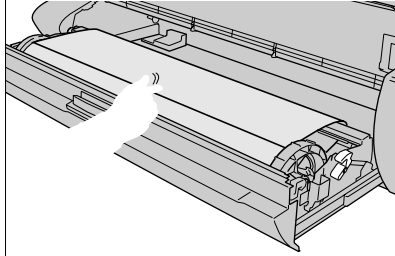

...roll holder in the direction of the arrow until the edge of the
...aches the edge of the paper guide.

...until approximately 1~2 mm of the leading edge of the roll
...le below the paper guide.

...the roll media tray, close the tray.

...the roll media tray completely into the printer.

...Type” is displayed on the operation panel.

- 8 Press ◀ or ▶ to select the setting for the type of media loaded in the printer then press Enter.



After selecting the Roll Media Type setting, the print starts preparation for the selected media.

■ Roll Media Jam During Printing or Cutting

- 1 Press and hold the Power button for 1 second or more until the Online lamp goes off, release the button, then switch the printer off.

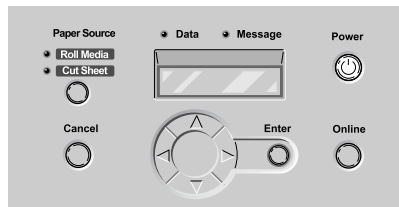

- 2 Open the upper cover.

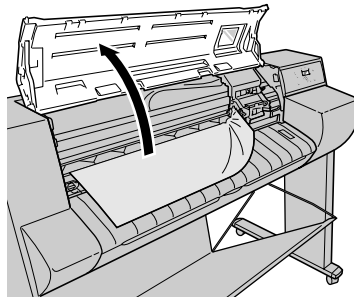

Important

- To avoid soiling your hands or damaging the printer, never touch any part inside the printer unless instructed to do so.

- 3** Move the carriage manually when it is out of its normally parked position.

Move it to the right or left edge of the carriage rail before attempting to remove the media.

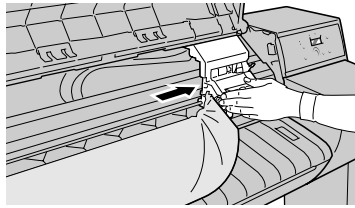

If the cutter is out of its normally parked position, manually move it to the left.

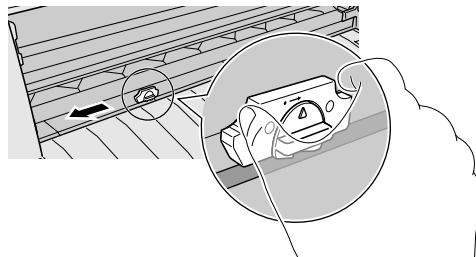

- 4** Raise the paper release lever.

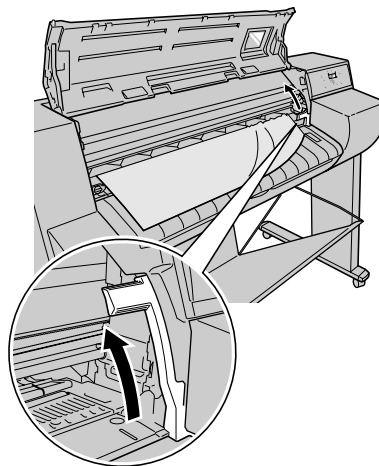

- 5** Hold the jammed sheet by the left and right edges and pull it toward you, then cut it where the printing ends or where it is wrinkled.

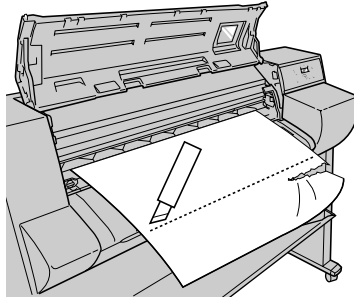

- 6** Open the tray, pull the tray open lever, then pull out the roll media tray.

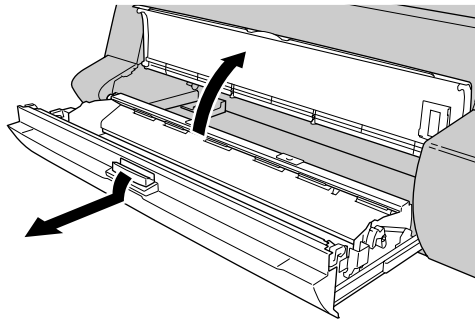

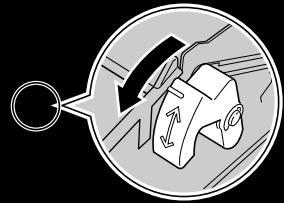

- 9** Rotate the roll holder in the direction of the arrow , then cut the media along the edge of the paper guide.

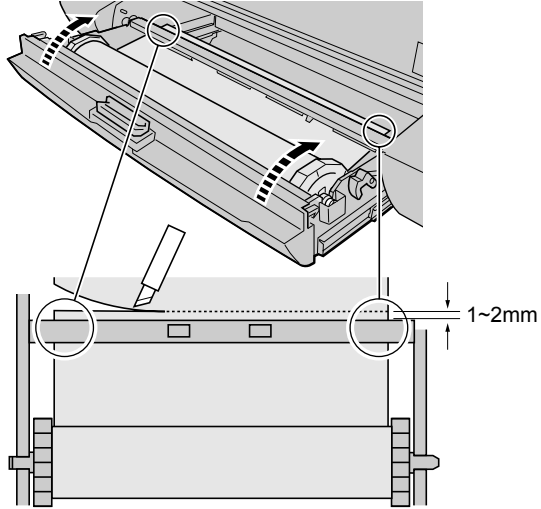

- 10** After closing the roll media tray, close the tray.
Firmly push the roll media tray completely into the printer.

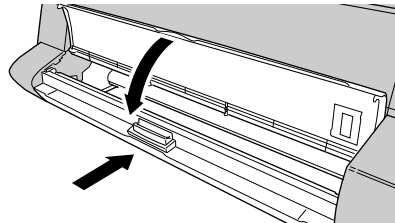

- 11** Lower the paper release lever, then close the upper cover.

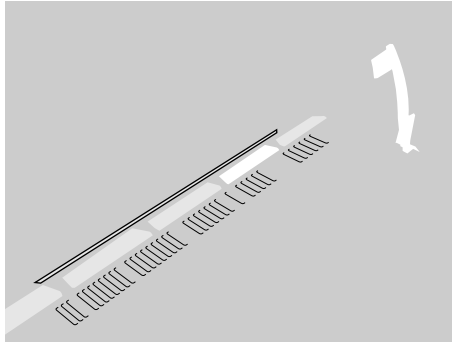

- 12** Press the Power button to switch the printer on.

Roll media preparation begins. When preparation is finished, the printer is ready to print.

 **Note**

- If you want a sharper leading edge, press the Online button on the operation panel to display “Offline”, then press ▼ to feed the media. On the MAIN MENU select “Force Cutting” to cut the leading edge of the media. (→ P.5-7)
- If you have just exchanged the roll media for a new type media, be sure to change the Roll Media Type setting. (→ P.2-18)

Removing a Cut Sheet Jam

Follow the procedure below to remove a cut sheet jam that occurs during printing.

- 1 Open the upper cover.

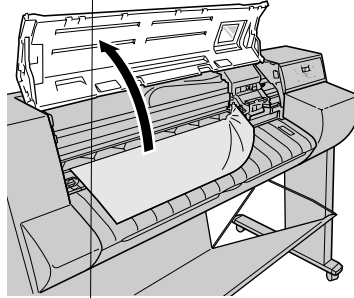

Important

- To avoid soiling your hands or damaging the printer, never touch any part inside the printer unless instructed to do so.

- 2 Raise the paper release lever.

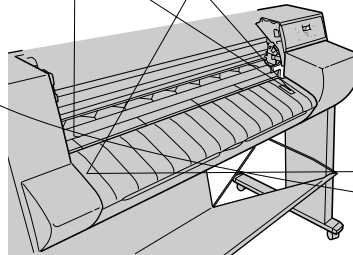

- 3** If the jammed sheet is visible, grip the sheet by the left and right sides and pull it toward you out of the printer.

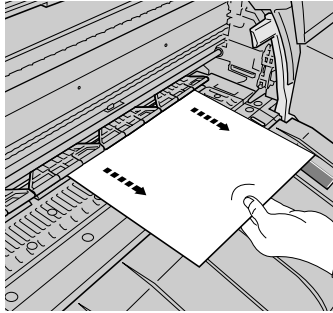

- 4** If the jammed sheet is not visible, on the back of the printer open the roll media guide then pull out the jammed sheet.

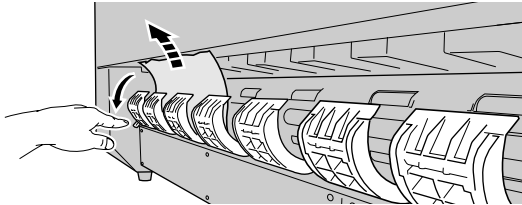

Visually inspect the area to make sure that no pieces of the sheet remain behind.

- 5** Load a new sheet of paper, then lower the paper release lever.

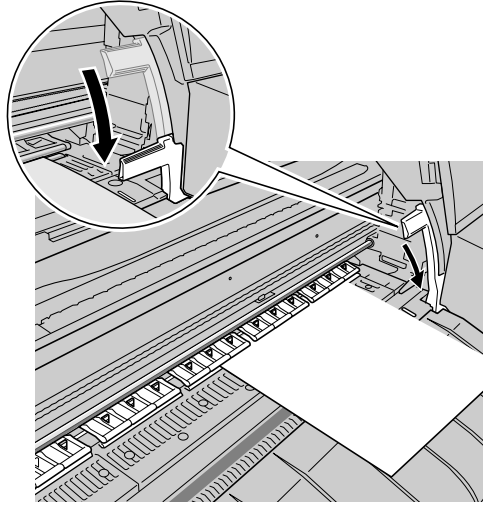

- 6** Close the upper cover.

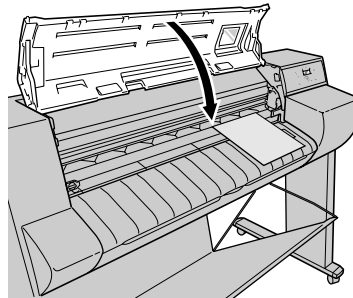

Cut sheet preparation begins. When preparation is finished, the printer is ready to print.

Checking the Print Status

If your printouts become faint or streaked with white lines, print a nozzle check pattern to determine if the print nozzles on the printhead are clogged. Before executing the nozzle check pattern, be sure at least one cut sheet or roll media A3 size or larger is loaded.

Note

- If you are using a cut sheet, make sure at least one sheet of unused A3 paper (not the blank side of used paper) or larger is set.

- 1 If the printer is off, press the Power button to switch it on.

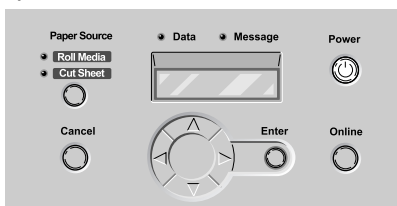

After a few seconds “Online” is displayed in the operation panel and the Online lamp lights.

- 2 Press the Online button twice to display “MAIN MENU”.

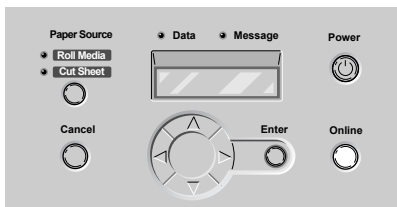

- 3 Press ◀ or ▶ to display “Test Print” then press ▼.



- 4** Press ◀ or ▶ to select “Nozzle Check” then press Enter button.



The nozzle check pattern prints. After the nozzle check pattern has printed “Online” is displayed in the operation panel and the printer is ready to print.

If there are no breaks in the vertical and horizontal lines for each color, the nozzle check pattern is normal.

Normal Print Pattern

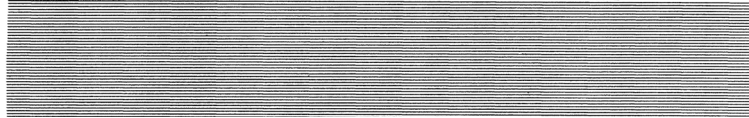

Abnormal Print Pattern

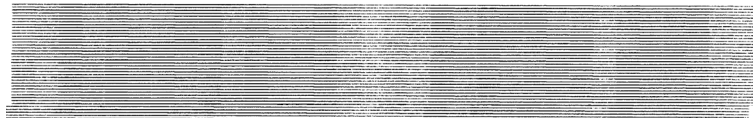

If any of the lines are broken, perform the following procedure:

- Execute printhead cleaning.
- Execute nozzle check pattern again.
- If cleaning the printhead does not solve the problem, call for service or contact the dealer where you bought the printer.

Cleaning the Printhead

When the ink nozzles of the printhead become clogged, you can restore normal operation by cleaning the printhead.

Types of Printhead Cleaning

There are two methods for printhead cleaning.

■ Head Cleaning A

Perform when the printing is faint or when dust has collected on the printhead. This cleaning method consumes the least amount of ink. Head Cleaning A requires about 1 minute to complete.

■ Head Cleaning B

Perform when the printing is blank or when Head Cleaning A does not correct the problem. Head Cleaning B requires about 2 minutes for the dye ink printer and about 3 minutes for the pigment ink printer.

Printhead Cleaning Procedure

Follow the procedure below to clean the printhead. The procedure is basically the same for both printhead cleaning methods.

- If one execution of Head Cleaning A does not correct the problem, perform Head Cleaning B.
- If Head Cleaning B does not correct the problem, repeat Head Cleaning B two or three times.
- If three consecutive cleanings with Head Cleaning B do not solve the problem, then the printhead is damaged and should be replaced.
(→ P.6-19)

- 1** Press the Power button to switch the printer on.



After a few seconds “Online” is displayed in the operation panel and the Online lamp lights.

- 2** Press the Online button twice to display “MAIN MENU”.

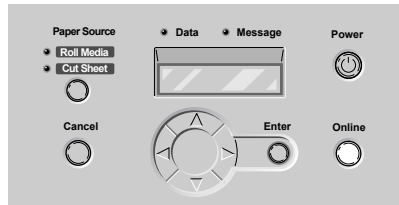

- 3** Press ◀ or ▶ to display “Head Cleaning” then press ▼.



- 4** Press ◀ or ▶ to select the cleaning method then press Enter.



Head cleaning begins. When head cleaning is finished, “Online” is displayed and the printer is ready to print.

- 5** Print the nozzle check pattern to determine if normal operation has been restored.

(→ “Checking the Print Status” P.7-31)

- 4** Press ◀ or ▶ to select “Adjust Printer” then press ▼.



- 5** Press ◀ or ▶ to select “Print Pattern A” then press Enter.



Pattern A is printed.

After the pattern has printed, “Adj.Setting A1” is displayed.

- 6** Look at Pattern A1 and determine the number of the vertical line that is least conspicuous. Press ◀ or ▶ to display that number then press Enter.



The selection is prefixed with an equals sign (=) to denote the current value of “A1”.

Sample: Conspicuous Vertical Line

-4
|||

Sample: Inconspicuous Vertical Line

0
|

- 7** Repeat Step 6 for Pattern A2 to A5, and B1 to C5 adjustments.

- 8** Look at Pattern D2, note the position and number of the line with the best alignment, Press ◀ or ▶ to select that number then press Enter. Press ▲ to return to the previous level above.



The selected setting prefixed with an equals sign (=) to denote the current value of “D2”.

Sample: Positioned Incorrectly

+10



Sample: Positioned Correctly

0



- 9** Repeat Step 8 for Pattern D3 to D5, and E2 to E5 adjustments. When you are finished making settings, the printer returns online.

Adjusting Amount of Media Feed

The amount of feed is adjusted for each media type. Printing Pattern B sets the amount of feed for the currently selected media type. Before printing, make sure that A3 or larger roll media is set.

Important

- Before adjusting the amount of media feed, you must use the operation panel to select the correct setting for the roll media type loaded in the printer. If the “Roll Media Type” selection is incorrect for the roll media set in the printer, this could cause poor print quality or possibly damage the printer.

Note

- If you are using a cut sheet, make sure at least one sheet of unused A3 paper (not the blank side of used paper) or larger is set.

- 1** If the printer is off, press the Power button to switch the printer on.

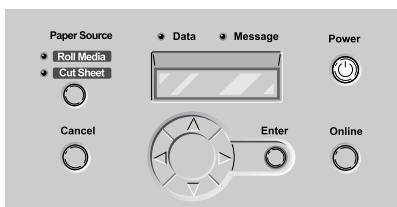

After a few seconds “Online” is displayed in the operation panel and the Online lamp lights.

- 2** Press the Online button twice to display “MAIN MENU”.

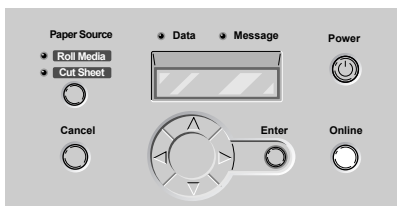

- 3** Press ◀ or ▶ to select “System Setup” then press ▼.



- 4** Press ◀ or ▶ to select “Adjust Printer” then press ▼.



- 5** Press ◀ or ▶ to select “Print Pattern B” then press Enter.



Pattern B prints.

After Pattern B prints, “Adj.Setting M” is displayed. This “M” setting is different for each media type. (→ P.5-12)

- 6** Look at Pattern B and determine the number of the vertical line that is least conspicuous. Press ◀ or ▶ to display that number then press Enter.



The selected setting is prefixed with a (=) mark to denote the current value for “M”.

Sample: Conspicuous Line

-4



Sample: Inconspicuous Line

+2



When you are finished making settings, the Online lamp lights and the printer is ready to print.



Important

- If it is difficult to judge the pattern with the least conspicuous lines, set the adjustment to the middle value.
(ex.) Set the value to +1 if the patterns of the values 0 and +2 are difficult to judge.

Reducing the Amount of Cut Waste

The cut waste reduction function allows you to reduce the amount of waste and paper dust created when cutting glossy film and other types of media that easily generate cutting waste. Using this function reduces the chance of poor print quality and lengthens the service life of the printhead. The cut waste reduction feature can be switched on or off for each type of media.

Important

- Switching on the cut waste reduction function draws a black line at the leading and trailing edges of roll media.
- Do not use this function with plain paper, thin paper, or paper that wrinkles easily. To avoid paper jams, do not use this function with cut sheets. This function cannot be used with cut sheets.

- 1 If the printer is off, press the Power button to switch the printer on.

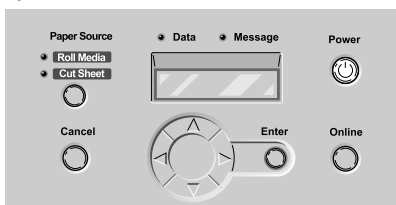

After a few seconds “Online” is displayed in the operation panel and the Online lamp lights.

- 2 Press the Online button twice to display “MAIN MENU”.

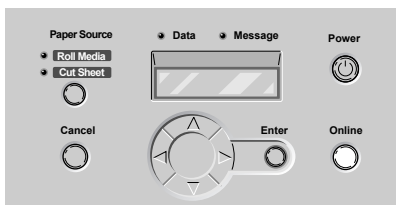

- 3** Press ◀ or ▶ to display “System Setup” then press ▼.



- 4** Press ◀ or ▶ to display “CutDustReduct.” then press ▼.



- 5** Press ◀ or ▶ to select the media type then press ▼.



- 6** Press ◀ or ▶ to select the setting then press Enter.

In order to enable the cut waste reduction function for the selected media, select “Yes”, or to disable the function select “No”.



The selection is prefixed with an equals sign (=) to denote that the cut waste reduction function is selected.

Replacing the Cutter Blade

Follow the procedure below to replace a dull blade that no longer cuts cleanly.

- 1 If the printer is off, press the Power button to switch the printer on.

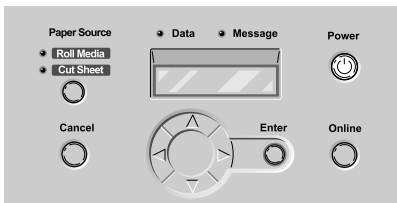

After a few seconds “Online” is displayed in the operation panel and the Online lamp lights.

- 2 Press the Online button to display “Offline”.

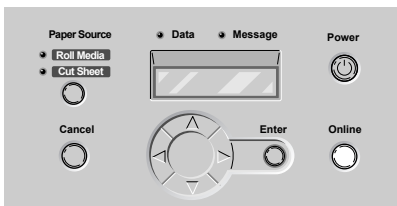

3 Open the upper cover

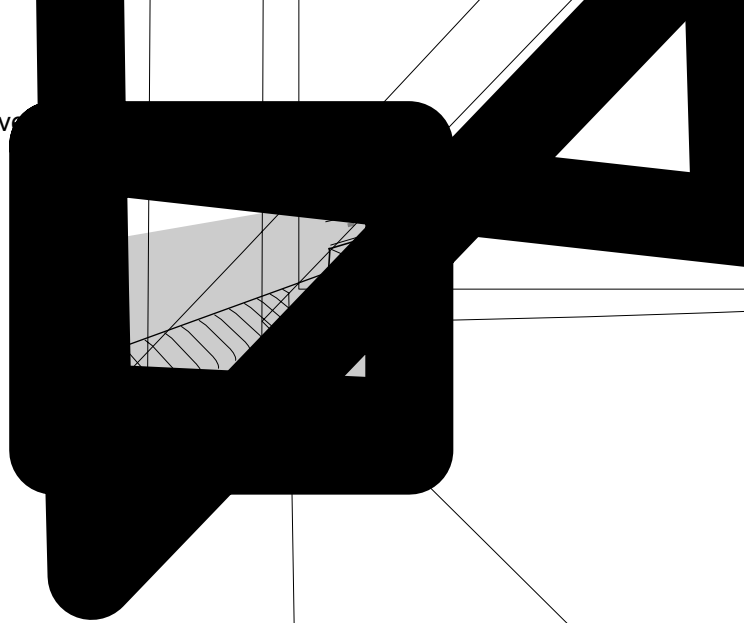

 **Important**

- To avoid soiling your hands or damaging the printer, never touch any part inside the printer unless instructed to do so.
- If the cutting area is dirty, use a damp cloth to clean the cutter unit before starting the procedure to replace the cutter blade.

4 While pinching the cutter blade at the grips, pull the cutter blade off from the cutter unit.

 **Important**

- To avoid personal injury from a cut, never touch the blade (a) after removing the cutter blade.

- 5** Align the arrow on the cutter blade with the arrow on the cutter unit, then insert the blade, turning it to the right to install it.

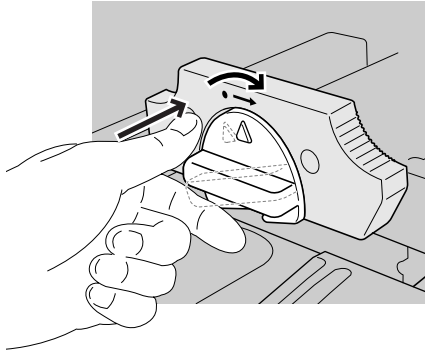

Important

- Turn the cutter blade to the right (clockwise), and make sure that you feel it click into the locked position (when it clicks it is locked). If the blade is installed incorrectly and not securely locked when in use, the blade could damage the printer or the printout.



Note

- Discard the used cutter blade in compliance with local laws and regulations regarding the disposal of such items.

- 6** Close the upper cover.

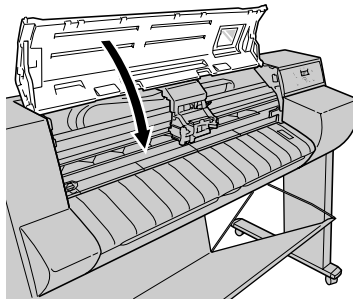



8

Other Important Information

This chapter describes options, specifications, and provides other information.

Options

The following options are provided for this printer.

Media Take-up Unit

The Media Take-up Unit, automatically takes up long sheets of media onto a roll as they are printed. This device is convenient when printing with roll media on very long sheets.

- Media Take-up Unit TU-03

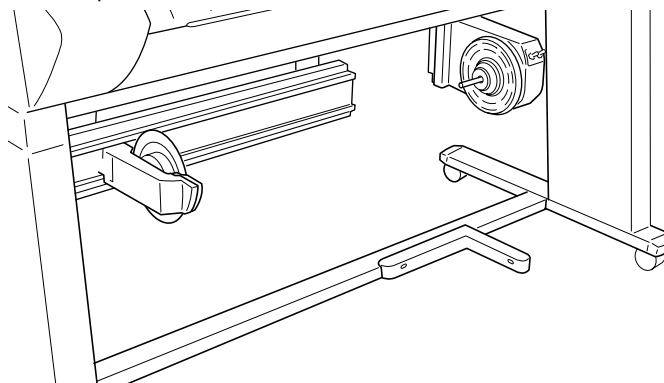

USB 2.0 Expansion Board

This board provides the USB 2.0 interface.

- Hi-Speed USB Interface Board EB-02

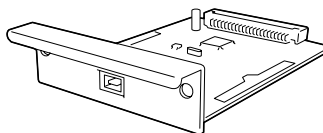

IEEE1394 Expansion Board

This board provides the IEEE1394 (FireWire) interface.

- IEEE1394 Expansion Board EB-01

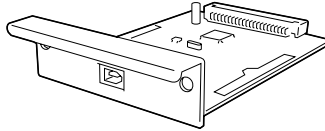

Roll Holder Sets

These sets contain a roll holder and holder stopper, just like the roll holder and holder stopper on the printer. These optional sets are designed for use with media of different types and widths. Having more than one type is convenient for handling differ sizes and types of media.

- Roll Holder Set RH2-41 (for 2 in. media core)

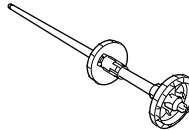

- Roll Holder Set RH3-41 (for 3 in. media core)

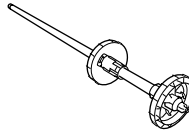

Consumables

This sections describes the consumables that are provided for use with this printer. You should stock the following items beforehand. For details about how to obtain consumables, call for service or contact the dealer where you bought the printer.

Print Media

The following media can be used with this printer.

■ Media Types

Dye ink printer

- Plain paper
- Coated paper
- Heavy coated paper
- Glossy paper
- Photo glossy paper
- Photo semi-glossy paper
- Glossy film
- Back Print Film
- Proofing paper

Pigment ink printer

- Heavy coated paper
- Photo glossy paper
- Photo semi-glossy paper
- Synthetic paper (Non-Adhesive)
- Synthetic paper (Adhesive)
- Back Light Film
- Flame-Resistant cloth

■ Roll Sizes

Width	ISO A3 (297.0 mm) ~ Non-Category 44" (1118 mm)
Roll diameter	Less than 130 mm (5.1 in.)
Media core inside diameter	2 in., and 3 in. (Options)
Print side	Front side

■ Cut Sheets

Sizes	ISO A4 ~ Non-Category 44" (1118 mm)
-------	-------------------------------------



Note

- For more details about print media, see Chapter 2, “Print Media That Can Be Used” (→ P.2-2).
- The quality of print media varies with the manufacturer. For details, contact the dealer where you bought the printer.

Ink Tanks

Six types of replaceable ink tanks are used in this printer.

- Dye Ink Tank

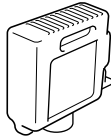

- Yellow Ink Tank BCI-1411Y
- Magenta Ink Tank BCI-1411M
- Photo Magenta Ink Tank BCI-1411PM
- Cyan Ink Tank BCI-1411C
- Photo Cyan Ink Tank BCI-1411PC
- Black Ink Tank BCI-1411Bk

- Pigment Ink Tank

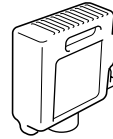

- Yellow Ink Tank BCI-1421Y
- Magenta Ink Tank BCI-1421M
- Photo Magenta Ink Tank BCI-1421PM
- Cyan Ink Tank BCI-1421C
- Photo Cyan Ink Tank BCI-1421PC
- Black Ink Tank BCI-1421Bk



Note

- For details about how to replace ink tanks, see Chapter 6, “Replacing Ink Tanks”, (→ P.6-2).

Printhead

The product number of the printhead that can be used on the printer are:

- Dye Ink Printhead

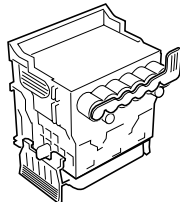

Printhead BC-1400

- Pigment Ink Printhead

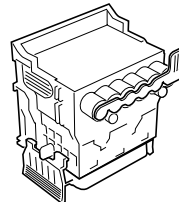

Printhead BC-1450



Note

- For details about how to replace the printhead, see Chapter 6, “Replacing the Printhead”, (→P.6-19).

Cutter Blade

The product number of the cutter blade that can be used on the printer are:

- Cutter Blade CT-03

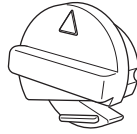

Note

- For details about how to replace the cutter blade, see Chapter 7, “Replacing the Cutter Blade”, (→ P.7-42).

Updating the Firmware

By updating the firmware for this printer, you can add on new functions and improvements for existing functions.

Obtaining the Firmware Update

Contact a Canon service center, or the dealer where you purchased the printer, for details about how to obtain the most recent version of the firmware update.

Confirming the Firmware Version

Before updating the firmware, follow the procedure below to confirm the version number of the current firmware update. If the version number of the current firmware update is older than the one in hand, then use the new program to update the firmware.

Note

- If the version number of the printer is the same as or newer than the firmware update in hand, then you do not need to update the firmware.

- 1** If the printer is off, press the Power button to switch the printer on. After a few seconds “Online” is displayed in the operation panel and the Online lamp lights.
- 2** Press the Online button twice to display “MAIN MENU”.
- 3** Press ◀ or ▶ to select “Information” then press ▼.

```
MAIN MENU
Information ▼
```

- 4** Press ◀ or ▶ to select “S/C :XX.XX.XX”.

```
Version
S / C : XX.XX.XX
```

The “XX.XX.XX” notation is the version number of the firmware update (system controller).

Uninstalling the Software

Follow the procedure below to uninstall the printer driver and utilities from computer.

Important

- If you uninstall the software from Windows XP, Windows 2000, or Windows NT 4.0, you must log in as a member of the Administrators group before the uninstallation.

Deleting Old USB/IEEE1394 Printer Drivers

Follow the procedure below when you need to remove an old version of a USB or IEEE1394 printer driver. All of the printers presented in the list at Step 3 will be deleted.

Important

- Before you uninstall an old version of a USB or IEEE1394 driver, be sure to disconnect the USB or IEEE1394 cable.

- 1** Mount the provided User Software CD-ROM in the computer CD-ROM drive.

Important

- If the CD-ROM auto start feature is switched off, double-click the My Computer icon on the desktop, double-click the CD-ROM icon, then from the File menu select Auto Play.

- 2** From the Setup Menu, select Uninstall Old USB/IEEE 1394 Driver.

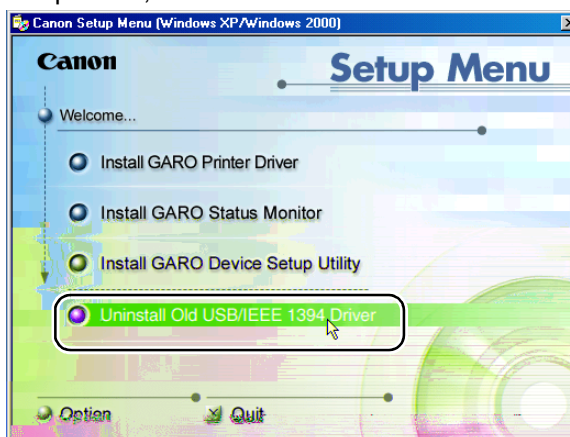

- 3 Delete all the printer drivers presented in the list. Confirm the names of the printers, then click the Yes button.

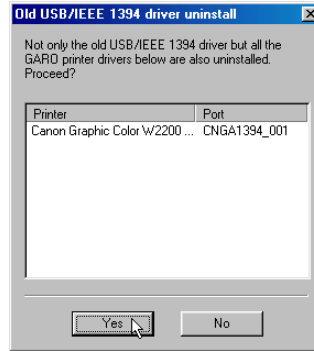

Uninstall begins.

- 4 When the uninstallation is finished, the printer names deleted from this list are displayed. Confirm the printer names, then click the OK button.

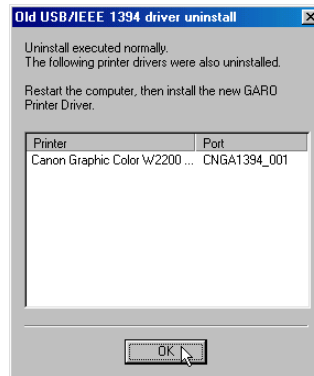

Follow the instructions on the screen to restart the computer.

 **Note**

- If a message warns you that the uninstallation failed, restart the computer, then mount the provided User Software CD-ROM into the CD-ROM drive. Repeat this procedure from Step 1.

This completes the deletion of the old USB or IEEE1394 drivers.

Uninstalling the Printer Driver

Follow the procedures below to uninstall the printer drivers.

■ Windows



Important

- If you uninstall the software from Windows XP, Windows 2000, or Windows NT 4.0, you must log in as a member of the Administrators group before the uninstallation.

- 1** On the desktop, click the Start button, point to Programs, then click “GARO Printer Driver Uninstaller” from “Canon Printer Uninstaller”. The Delete Printer window opens.
- 2** Click the printer in the list you wish to delete, then click the Delete button.
Confirmation message appears.
- 3** Click the Yes button.
- 4** Make sure that the printer is deleted from the list, then click the Exit button in the Delete Printer window.

■ Macintosh

- 1** Mount the User Software CD-ROM in the CD-ROM drive.
- 2** On the User Software CD-ROM, open the appropriate OS folder.
For OS 8.x or OS 9.x, in the OS89 folder, open “GARO Installer for 8/9”.
For OS X, in the OSX folder, open “GARO Installer for X”.
- 3** From the menu on the upper left side, select Uninstall, then click the Uninstall button.
- 4** Follow the messages on the screen to delete the GARO Printer Driver.

Uninstalling GARO Status Monitor

Follow the procedure below to uninstall GARO Status Monitor from a Windows system.

- 1** On the desktop, click the Start button, point to Programs, then click Uninstall GARO Status Monitor for GARO Status Monitor.
- 2** Click the OK button after the confirmation message is displayed. GARO Status Monitor is deleted.
- 3** Click the finish button after the InstallShield Wizard complete is displayed.

Uninstalling an LPR Port

Follow the procedure below to uninstall Canon LPR Port installed with Windows.

- 1** Use the printer driver to select and set the printer for any port (“Print to the following port”) other than Canon LPR Port.
This selection can be performed on the Details sheet of the Printer Properties dialog box.
For the CANON LPR Port, “XXX.XXX.XXX.XXX@LP (Canon LPR Port)” is displayed.
- 2** Mount the provided User Software CD-ROM in the CD-ROM drive.
- 3** Double-click and execute UnInstLP.exe in the Lprport folder in the User Software CD-ROM.
- 4** Follow the messages on screen to complete removal of the LPR Port.

Uninstalling the GARO Device Setup Utility

Follow this procedure to uninstall the GARO Device Setup Utility installed with Windows.

- 1** On the desktop click the Start button, point to Settings, then click Control Panel.
The Control Panel window opens.

- 2** Double-click the Add/Remove Programs icon.

- 3** Select GARO Device Setup Utility from the list of software applications then click the Change/Remove button.

- 4** Follow the messages on screen to complete removal of GARO Device Setup Utility.

Specifications

	Dye ink	Pigment ink
Printing Characteristics		
Print Method		Serial Bubble Jet

	Dye ink	Pigment ink
Margins	Top: 20 mm (0.79 in.) Bottom: 23 mm (0.91 in.) Left: 5 mm (0.2 in.) Right: 5 mm (0.2 in.)	
Output Stacker capacity	1 sheet	
Main Unit		
Power source	AC100-240 V 1.6A 50/60 Hz	
Power Consumption	Maximum 160 W Standby/Sleep mode: Less than 30 W*3	
Noise (Operation)	Less than 55 dB (A) (High quality print mode)	
Ideal operating environment	15 ~ 30 °C (59 ~ 86 °F), 10~80 % RH with no condensation*4	
Operating environment	5 ~ 35 °C (41 ~ 95 °F), 10~90 % RH with no condensation	
Dimensions (w x d x h)		
Printer only	1842 x 533 x 464 mm (72.5 x 21 x 18.3 in.)	
Printer + Stand	1842 x 860 x 1175 mm (72.5 x 33.9 x 46.3 in.)	
Weight (including printhead, ink tanks)		
Printer only	approx. 85.0 kg (approx. 187 lb.)	
Printer + Stand	approx. 112.0 kg (approx. 246.4 lb.)	
Take-up Unit (Option) Specifications		
Power Source	Supplied from main unit	
Control System	Independent	
Take-up Roll	1	
Media Type	Coated Paper, Heavy Coated Paper, Glossy Paper, Proofing Paper, Photo Glossy Paper, Photo Semi-Glossy Paper	Heavy coated paper, Photo glossy paper, Photo semi-glossy paper, Synthetic paper (Adhesive), Back Light Film, Flame-Resistant cloth
Media Width	24" (A1), 36" (A0), 42", 44"	
Media Length	Max. 50 m (Outer circumference: 150 mm)	
Media Core Inside Diameter	2" or 3" (option)	

*1. If you print on the Proofing Paper, use the optional software RIP.

*2. The environment below is required for use of the USB 2.0 (Hi-Speed) interface:

- Computer: Compatible with USB 2.0 Hi-Speed
- Operating System: Windows XP or Windows 2000
- USB 2.0 Driver: Microsoft USB 2.0 driver (You can acquire the Microsoft USB 2.0 driver from Windows Update or Service Pack.)
- USB Cable: USB 2.0 adapted cable
- Here is a list of Adaptec USB 2.0 compliant expansion cards whose operation has been confirmed by Canon with a standard USB driver running on the Microsoft operating system:
 - USB2CONNECT3100
 - USB2CONNECT5100
 - USB2CONNECT2000LP

*3. With the power supply off, a small amount of power is consumed. To power off the printer completely, switch the printer off and disconnect the printer power cord from the power source.

*4. Use Back Print Film only when ambient humidity is 30% to 80%.

- These specifications are subject to change for improvements.
- The above specifications may vary for different operating environments.
- When printing is done at 300 x 300 dpi resolution when printing with Macintosh OS 8/9 on paper larger than the B0 size.

Index

Symbols

▲ Button	5-5
▼ Button	5-4
◀ Button	5-4
▶ Button	5-4

A

Acrobat Reader	4-13
ANSI	2-5
AppleTalk	4-3
ARCH	2-5

B

Back Light Film	2-4
Back Print Film	2-3
background printing	4-7
belt stopper holder	1-6

C

Cancel button	3-4, 4-9, 4-11, 4-12, 5-4
canceling printing	
Macintosh	4-7
Windows	3-4
carriage	1-5, 7-23
carriage cover	1-5, 6-22
carriage rail	1-4, 6-17
carriage rail cleaning	6-16
checking print status	7-31
Chooser	4-2
cleaning covers	6-9
Coated Paper	2-3
consumables	8-4
Cut Sheet lamp	2-20, 5-6
cut sheets	2-5, 2-19
jams	7-28
loading	2-21
selecting type	2-26
sizes	8-4
cut waste reduction	7-40
cutter adjustment	7-42
cutter blade	7-43, 8-6

D

Data lamp	5-6
Deleting Old USB/IEEE1394 Printer Drivers	8-8
DIP switches	1-3
display	5-2

	Dye ink	2-2, 2-16, 2-24, 5-10
	Dye Ink Printhead	8-5
	Dye Ink Tank	6-2, 8-5
E		
	Enter button	5-5
F		
	firmware update	8-7
	Flame-Resistant Cloth	2-4
	foreground printing	4-12
	function menus	
	operation	5-8
	settings	5-10
	structure	5-7
G		
	GARO Device Setup Utility	8-12
	GARO Printer Driver	4-3
	GARO Status Monitor	3-4
	uninstall	8-11
	glossy film	2-3, 2-27
	glossy paper	2-3
H		
	Heavy Coated Paper	2-3
	Help	
	Macintosh	4-13
	Windows	3-5
	high quality image print	2-27
	holder stopper	2-10
I		
	IEEE1394 Expansion Board	8-3
	ink level detection function	6-8
	ink tank cover	6-5
	ink tank covers	1-7
	ink tanks	1-7, 6-2, 6-5, 8-5
	handling precautions	6-3
	replacement procedure	6-4
	when to replace	6-2
	ISO	2-5
J		
	jams	7-19
	JIS	2-5
L		
	lamps	5-6
	LAN port	1-3
	left cover	1-2

lift handles	1-3
LINK lamp	1-3
LPR Port	8-11

M

Mac OS 8.6/9.x	4-2, 4-7
Mac OS X	4-4, 4-9
Macintosh	4-2, 8-10
main menu	5-7, 5-10
media	8-4
printing area	2-7
problems	7-19
media feed adjustment	7-38
media size	2-5
media source setting	2-8, 2-19
Media Take-up Unit	1-8, 2-31, 2-37
connector	1-4
not use setting	2-43
settings	2-32
media type	2-2, 8-4
media type settings	2-16, 2-24
Message lamp	5-6
Messages	7-13

N

nozzle check print	7-31
--------------------------	------

O

offline	1-12
online	1-11
Online button	1-11, 1-12, 5-5
Online lamp	5-6
operation buttons	5-4
operation panel	1-3, 5-2
options	8-2
output stacker	1-2, 2-33, 2-43

P

paper guide	1-6, 2-13, 7-20, 7-26
paper release lever	1-4, 2-21, 6-12, 7-23, 7-28
paper restraint	1-4, 2-22
cleaning	6-14
Paper Source button	2-9, 2-20, 5-4
Photo Glossy Paper	2-3
Photo Semi-Glossy Paper	2-3
Pigment ink	2-2, 2-16, 2-24, 5-10
Pigment Ink Printhead	8-5
Pigment Ink Tank	6-2, 8-5
Plain Paper	2-2
platen	1-4, 6-12

Power button	1-9, 1-10, 5-5
power connector	1-4
power off	1-10
power on	1-9
Print Center	4-4
Print Pattern A	7-36
Print Pattern B	7-39
Print Queue Restarting	4-8
printer	
cleaning	6-9
parts name	1-2
specifications	8-13
printer driver	3-2, 4-2
printer function priorities	5-7
printer operation	7-3
printer selection	4-2
printhead	1-5, 6-19, 6-23, 8-5
alignment	7-35
cleaning	7-33
handling precautions	6-19
height adjustment	2-27
replacement procedure	6-20
printhead cleaning	
procedure	7-33
types	7-33
printhead height adjustment lever	2-29
printhead lock cover	1-5, 6-22
printhead lock lever	1-5, 6-22
printing	
Macintosh	4-6
Windows	3-2
Proofing Paper	2-3

R

rail cleaner	6-17
right cover	1-3, 1-7, 6-7
roll holder	1-6, 2-10, 7-19, 7-26
Roll Holder Sets	8-3
roll media	2-5, 2-8
installing	2-33
jams	7-22
loading	2-9
removing	2-39
Roll Media lamp	2-9, 5-6
roll media sizes	8-4
roll media tray	1-2, 2-10, 7-19, 7-24
roll media type setting	2-18
roll media window	1-3
roll release lever	1-6, 2-12
roll stopper	1-6

S

sensor unit	1-8
slide holder	1-8, 2-33, 2-42
slide holder release lever	1-8, 2-33, 2-42
software	8-8
stand	1-2
Synthetic Paper (Adhesive)	2-4
Synthetic Paper (Non-Adhesive)	2-4

T

take-up holder	1-8, 2-34
take-up mode switch	1-8, 2-33, 2-40
take-up switch	1-8, 2-37, 2-42
tray	1-2, 1-6, 2-19, 6-12, 7-19, 7-24
tray open lever	1-6, 7-19, 7-24
troubleshooting	7-2

U

Uninstalling the GARO Device Setup Utility	8-12
upper cover	1-2, 1-5, 2-21, 2-28, 6-11, 6-17, 6-21, 7-22, 7-28, 7-43
cleaning inside	6-11
parts inside	1-4
upper cover handle	6-12
upper cover roller	6-12

W

weight roll	2-38, 2-40
Windows	3-2, 8-10